



E-LINE KD

Data Rack Busbar Systems 160A...1000A



DATA RACK BUSBAR

E-LINE KD

DATA RACK BUSBAR

Please visit our website for the updated version of our catalogs.
www.eaelectric.com

CONTENTS

►► E-LINE KD

Overview	2-5
Technical Characteristics	6-7
Order Code System	8
Standard Length.....	9
Special Length.....	9
Aluminium Closure Panel	9
End Closer.....	9
Elbows.....	10-11
Feeder Boxes	
Feeder Box B10	12
Feeder Box B11	13
Tap-Off Boxes	
KDP Terminal Box	14
KDP Single Socket Box.....	15
KDP Double Socket Box.....	15
KDP Energy Analyzer Box.....	16
KDP Empty Box.....	16
KDP 1226 Energy Analyzer Box Horizontal	17
KDP 1226 Empty Box Horizontal	17
Installation	
Joint Installation.....	19
Tap-Off Box Installation	20
Tap-Off Box Horizontal Installation	21
Fixing Elements	
Application I : Threaded Rod with Snap-In Fixing Unit.....	22
Application II : TMP Ceiling Support with Snap-In Fixing Unit.....	22
Application III: TMP Ceiling Support and Tray Bracket with Snap-In Fixing Unit	23
Ceiling Mounting Fittings	24
Tray Supports.....	24
Connection Accessories.....	25
Measuring a Special Length.....	26
Busbar Installation Applications	27
Certificates	28
Declaration	29
Product Overview	30

E-LINE KD

►► Overview

To power the mission critical IT infrastructures on the Data Rack Cabinets, EAE offers a highly flexible and reliable Busbar System to meet the "Scalability" challenge in the Data Centers finding the way to Moves, Adds and Changes (MACs).

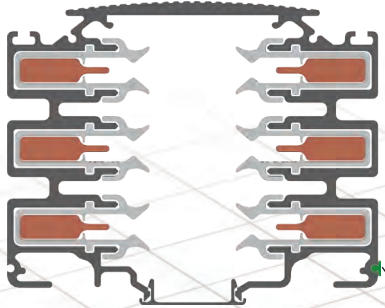

Al or Cu conductor options with whisker free coating



Front Side

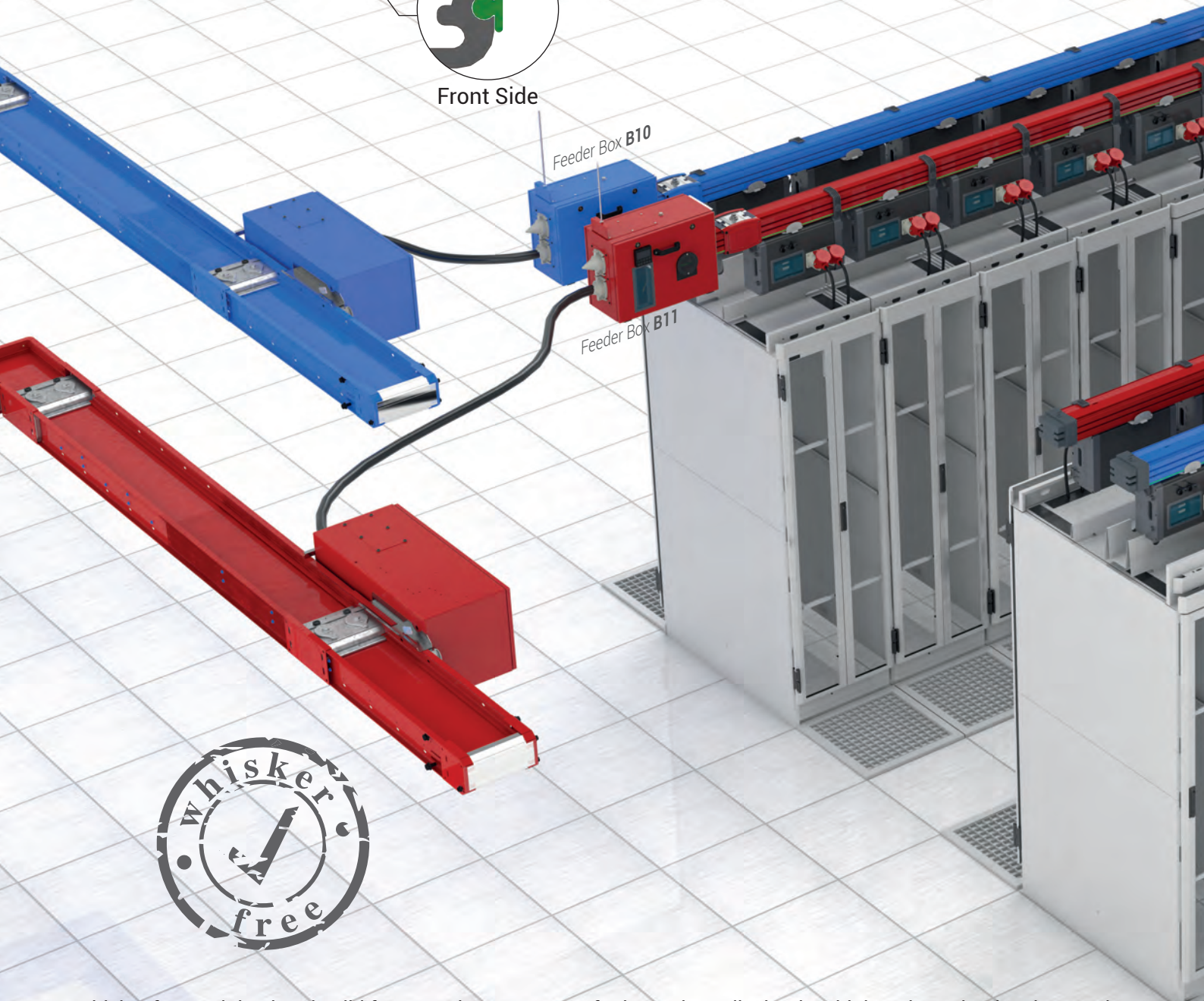

Whisker free and tin plated solid form conductors ensure for better heat dissipation, higher short circuit values and longer operation life while significantly contributing to the "Availability" challenge in the data center environments

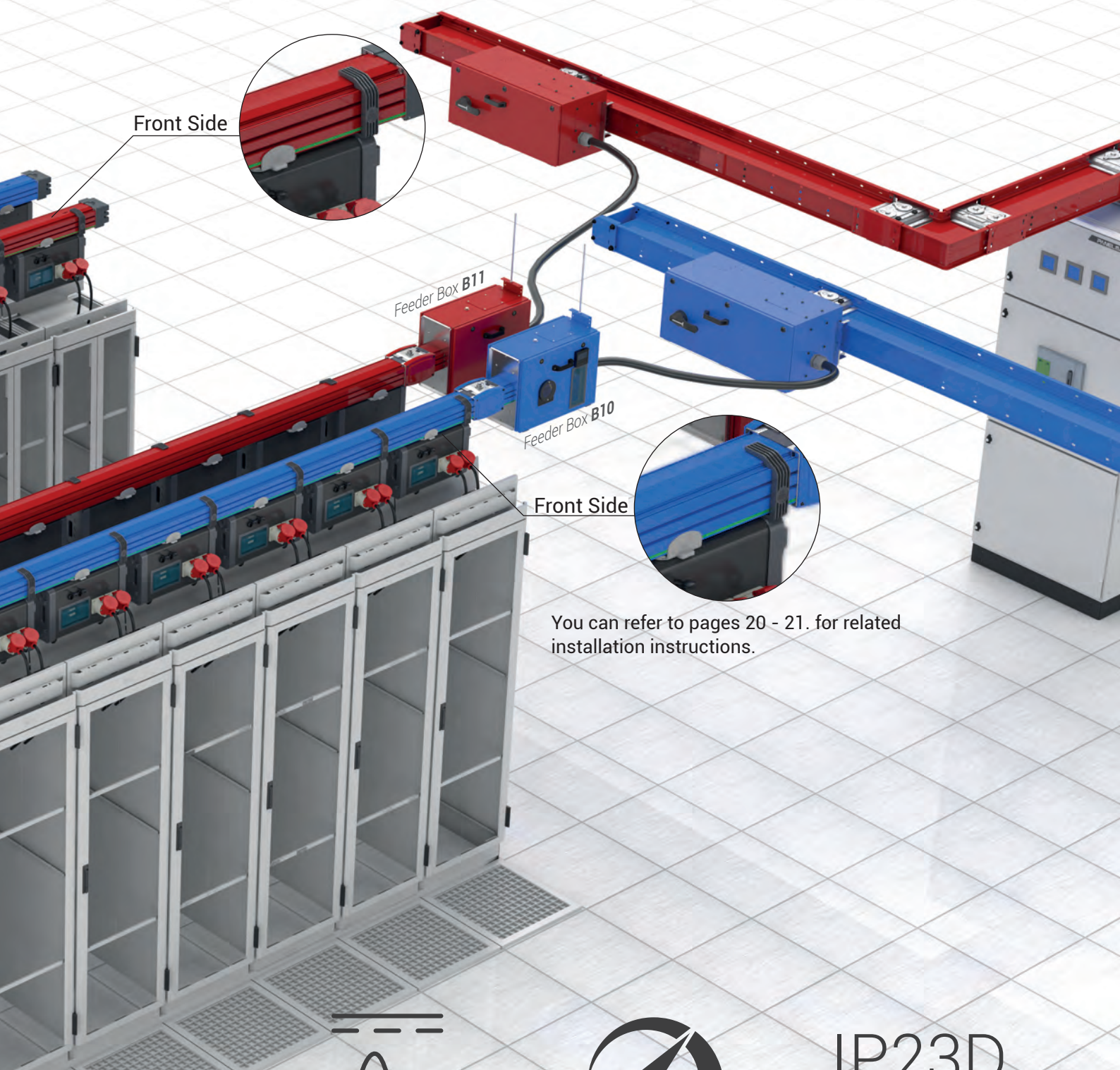

Front Side

Feeder Box B11

Feeder Box B10

Front Side

You can refer to pages 20 - 21. for related installation instructions.



AC or DC feeding



Energy monitoring

IP23D

IP23D protection

E-LINE KD

►► Overview

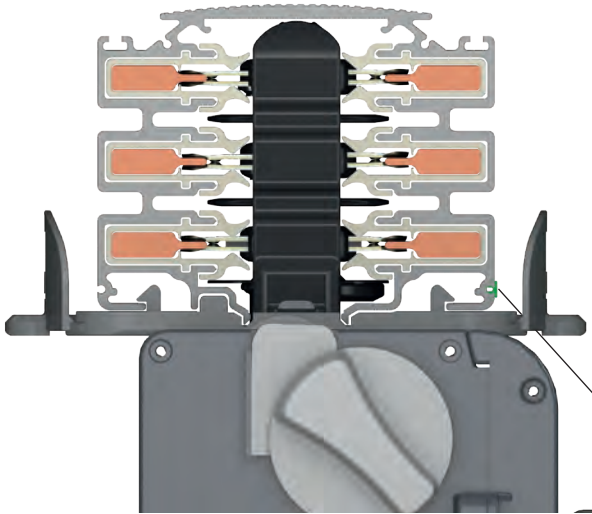

Plug-n-Play

Easy plug-in Tap-Off Boxes on any point along the busbar, remove and relocate wherever necessary

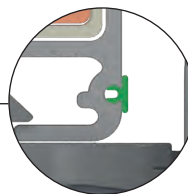

Front Side

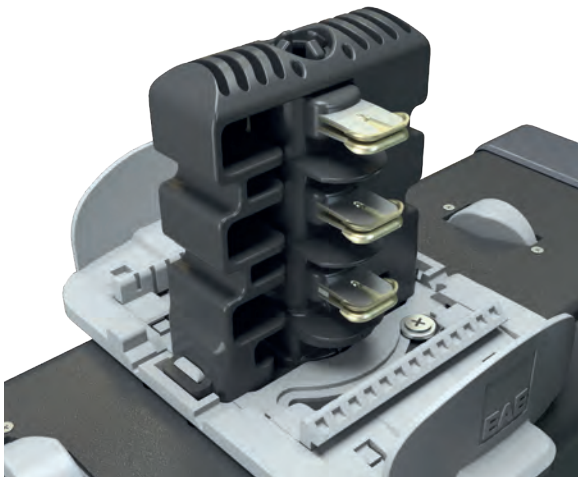

Tap-Off Contacts

Constant contact pressure with double sided spring system and safe locking mechanism on Tap-Off Box contacts



Snap-In Suspension Mechanism

Easy and fast structural mounting thanks to Snap-In Fixing Unit

E-LINE KD

►► Overview

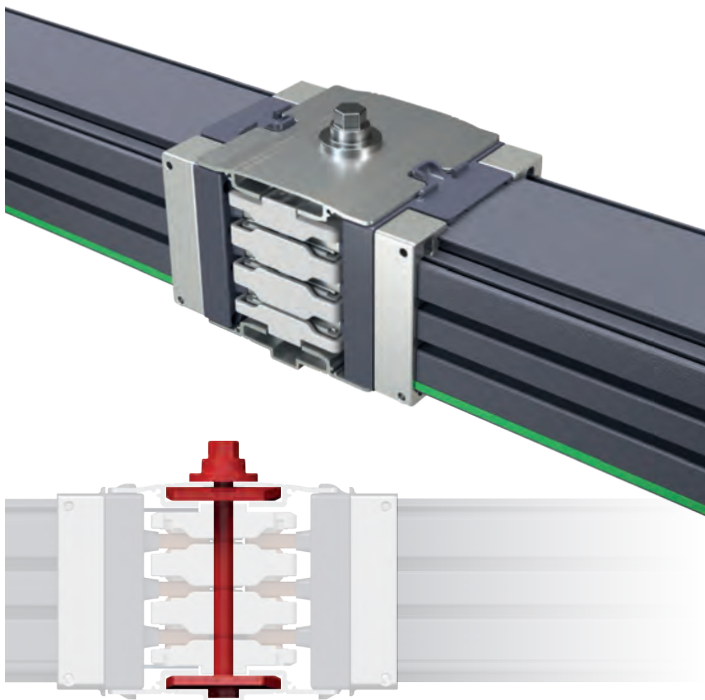

Joint Mechanism

Safe alignment mechanism with a single bolt monoblock joint for correct installation and operation

Front Side

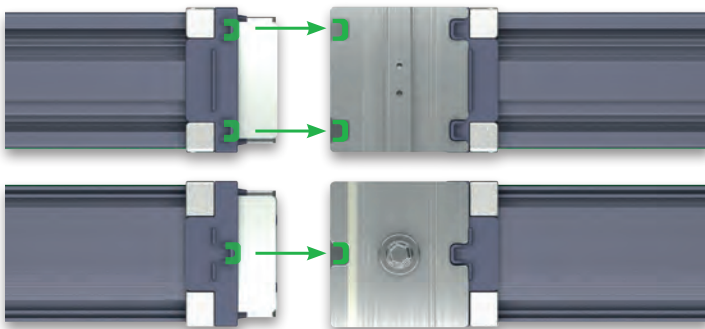

Easy and Safe Installation

Patented EAE Alignment Solution, ideal alignment of the block joint element and busbar thanks to the alignment guides on the joint area



Standards	IEC 61439-6, TS EN 61439-6, IEC 61439-1, TS EN 61439-1
Rated Isolation Voltage	Ui: 1000 V at Cat IV
Max. Rated Operational Voltage	Ue: 1000 Vac
Rated Impulse Withstand Voltage	Uimp: 12 kV
Rated Frequency	f: 50 Hz
Pollution Degree	III
Protection Degree	IP23D
External Mechanical Impacts (IK Code)	IK08
Protection for Safety	Basic Protection (HD 60364-4-41, Clause A1)

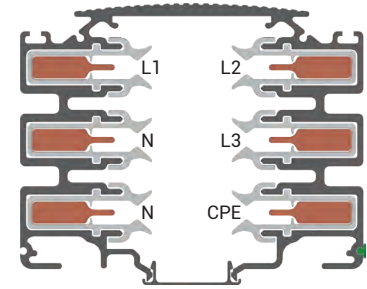

			AI				
RATED CURRENT	I_n	A	160	250	400	630	250
BUSBAR CODE			01	02	04	06	02
MEAN PHASE CONDUCTOR CHARACTERISTICS AT RATED CURRENT	ENT I_n						
Resistance at a conductor temperature of 20 °C	R_{20}	mΩ/m	0,358	0,352	0,234	0,159	0,215
Average resistance at I_n , thermal balance	R	mΩ/m	0,403	0,426	0,299	0,220	0,246
Reactance (Independent from Temperature)	X	mΩ/m	0,098	0,100	0,087	0,077	0,100
Positive and negative sequence impedances at an ambient air temperature of 35 °C	Z	mΩ/m	0,415	0,437	0,311	0,233	0,265
Positive and negative sequence impedances at a conductor temperature of 20 °C	Z_{20}	mΩ/m	0,371	0,366	0,249	0,177	0,237
Rated Power Loss at I_n		W/m	30,08	76,9	140	252,4	43,74
Aluminium Housing Section (Aluminium)		mm ²	3302	3302	3302	3302	3302
Busbar Weight (4 Conductors)		kg/m	11,1	11,1	11,8	12,6	13,6
Busbar Weight (5 Conductors)		kg/m	11,4	11,4	12,2	13,3	14,6
Busbar Weight (6 Conductors)		kg/m	11,6	11,6	12,6	14,0	15,3
MEAN FAULT-LOOP CHARACTERISTICS							
ZERO-SEQUENCE IMPEDANCE							
Zero-sequence impedance at a conductor temperature of 20 °C	$Z_{(0)b20phN}$	mΩ/m	1,482	1,482	1,016	0,725	0,949
Zero-sequence impedance at a conductor temperature of 20 °C (Housing)	$Z_{(0)b20phPE}$	mΩ/m	0,701	0,701	0,350	0,287	0,367
Zero-sequence impedance at a conductor temperature of 20 °C (Double Notr)	$Z_{(0)b20ph2N}$	mΩ/m	0,988	0,988	0,686	0,510	0,649
Zero-sequence impedance at a conductor temperature of 20 °C (CPE)	$Z_{(0)20phCPE}$	mΩ/m	1,509	1,509	1,039	0,743	0,962
Zero-sequence impedance at an ambient temperature of 35 °C	$Z_{(0)bphN}$	mΩ/m	1,659	1,775	1,272	0,968	1,063
Zero-sequence impedance at an ambient temperature of 35 °C (Housing)	$Z_{(0)bphPE}$	mΩ/m	0,787	0,844	0,441	0,389	0,416
Zero-sequence impedance at an ambient temperature of 35 °C (Double Notr)	$Z_{(0)bph2N}$	mΩ/m	1,106	1,184	0,856	0,680	0,727
Zero-sequence impedance at an ambient temperature of 35 °C (CPE)	$Z_{(0)bphCPE}$	mΩ/m	1,689	1,807	1,300	0,989	1,077
RESISTANCES AND REACTANCES							
Resistance at a conductor temperature of 20 °C	$R_{b20phph}$	mΩ/m	0,722	0,722	0,483	0,346	0,433
Resistance at a conductor temperature of 20 °C	R_{b20phN}	mΩ/m	0,718	0,718	0,479	0,342	0,434
Resistance at a conductor temperature of 20 °C (Double Notr)	$R_{b20ph2N}$	mΩ/m	0,558	0,558	0,373	0,274	0,340
Resistance at a conductor temperature of 20 °C (Housing)	$R_{b20phPE}$	mΩ/m	0,473	0,473	0,271	0,207	0,261
Resistance at a conductor temperature of 20 °C (CPE)	$R_{b20phCPE}$	mΩ/m	0,723	0,723	0,485	0,343	0,427
Resistance at an ambient air temperature of 35 °C	R_{bphph}	mΩ/m	0,815	0,875	0,618	0,479	0,494
Resistance at an ambient air temperature of 35 °C	R_{bphN}	mΩ/m	0,809	0,869	0,613	0,473	0,496
Resistance at an ambient air temperature of 35 °C (Double Notr)	R_{bph2N}	mΩ/m	0,629	0,676	0,478	0,378	0,389
Resistance at an ambient air temperature of 35 °C (Housing)	R_{bphPE}	mΩ/m	0,533	0,572	0,347	0,286	0,298
Resistance at an ambient air temperature of 35 °C (CPE)	R_{bphCPE}	mΩ/m	0,815	0,875	0,620	0,475	0,488
Reactance (Independent from temperature)	X_{bphph}	mΩ/m	0,194	0,194	0,169	0,141	0,196
Reactance (Independent from temperature)	X_{bphN}	mΩ/m	0,199	0,199	0,170	0,140	0,197
Reactance (Double Notr) (Independent from temperature)	X_{bph2N}	mΩ/m	0,152	0,152	0,135	0,114	0,157
Reactance (Housing) (Independent from temperature)	X_{bphPE}	mΩ/m	0,103	0,103	0,086	0,075	0,102
Reactance (CPE) (Independent from temperature)	X_{bphCPE}	mΩ/m	0,199	0,199	0,173	0,145	0,214

►Housing Type 1: 160A...630A (Al); 250A...800A (Cu)

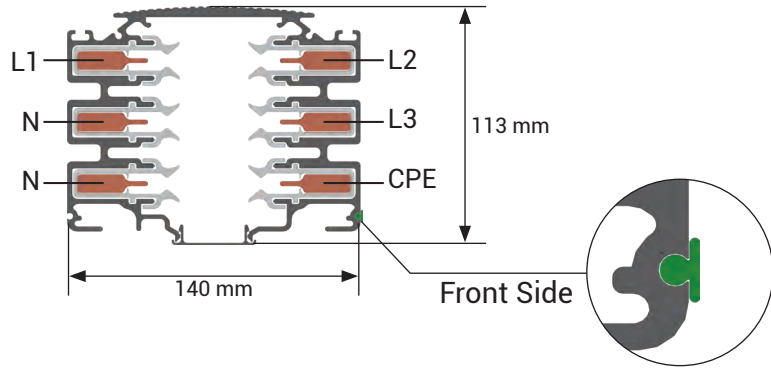

►Housing Type 2: 1000A (Cu)

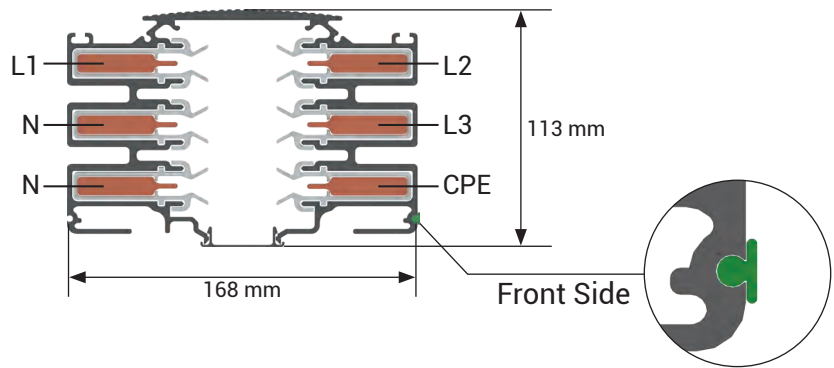

Cu			
400	630	800	1000
04	06	08	10
0,211	0,140	0,101	0,080
0,274	0,198	0,139	0,107
0,101	0,090	0,077	0,070
0,292	0,218	0,159	0,127
0,234	0,167	0,127	0,105
127,48	228,29	257,01	325
3302	3302	3302	3565
13,6	11,6	14,3	26,43
14,6	13,0	17,0	29,68
15,3	14,3	18,3	32,94
0,949	0,682	0,501	0,363
0,367	0,292	0,193	0,151
0,649	0,485	0,358	-
0,962	0,707	0,518	0,374
1,191	0,902	0,636	0,445
0,470	0,400	0,256	0,195
0,814	0,643	0,456	-
1,206	0,934	0,659	0,456
0,433	0,305	0,222	0,156
0,434	0,301	0,219	0,153
0,340	0,241	0,178	-
0,261	0,192	0,136	0,1
0,427	0,305	0,223	0,155
0,562	0,430	0,305	0,207
0,564	0,424	0,301	0,203
0,442	0,339	0,245	-
0,339	0,271	0,187	0,133
0,555	0,430	0,307	0,206
0,196	0,170	0,143	0,112
0,197	0,170	0,141	0,111
0,157	0,137	0,113	-
0,102	0,088	0,072	0,054
0,214	0,174	0,146	0,115

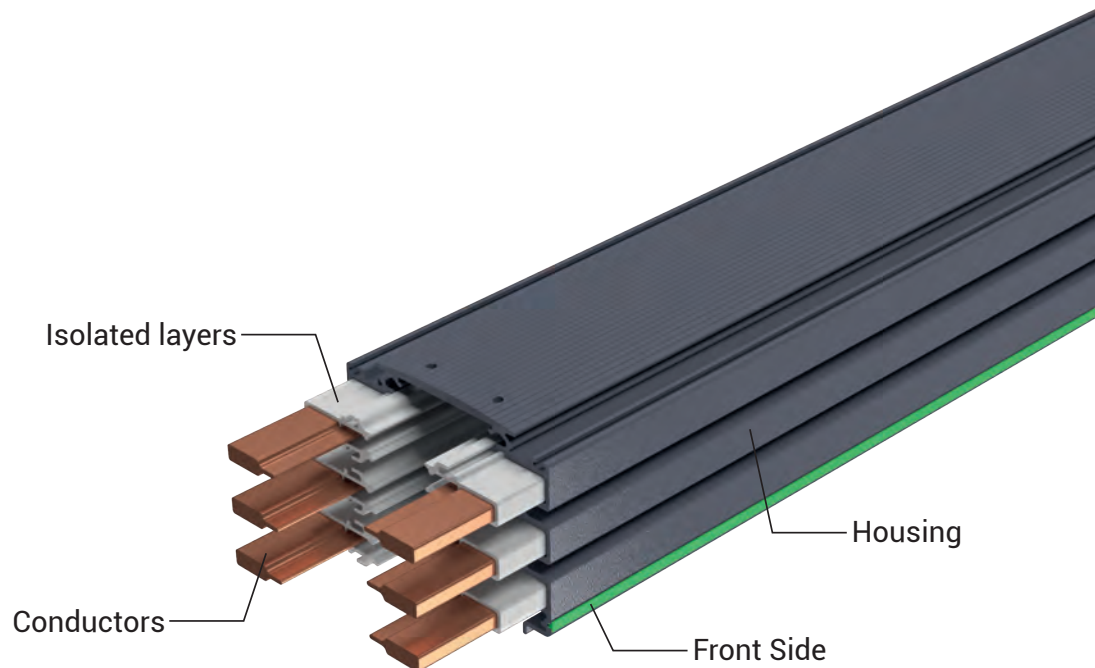

E-LINE KD

►►Order Code System

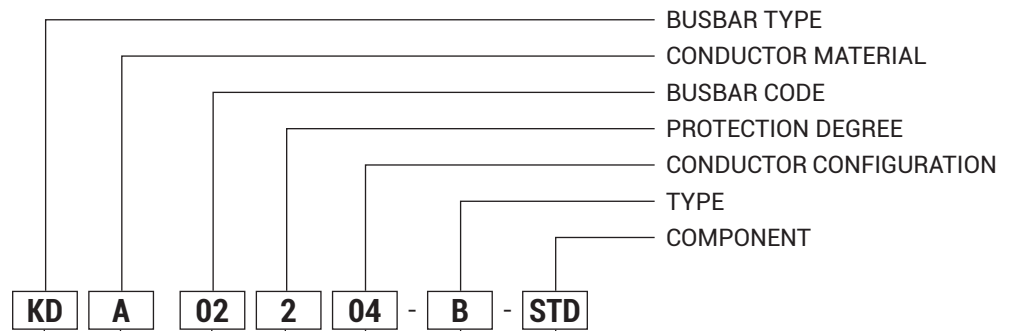

Busbar Type

Aluminium (Al) **A**
Copper (Cu) **C**

Al Conductor		Cu Conductor	
Rated Current	Busbar Code	Rated Current	Busbar Code
160	01	-	-
250	02	250	02
400	04	400	04
630	06	630	06
-	-	800	08
-	-	1000	10

IP23D

Standard Length	STD
Special Length	X
Feeder Box	B10
Feeder Box	B11
End Closer	S
Left Elbow	L
Right Elbow	R
Central Feeder	TO
Left Side Feeder	TYL
Right Side Feeder	TYR

Type	
Painted	B

Conductor Configuration								
Conductors	Code	L1	L2	L3	N1	N2	CPE	PE (Housing)
4 Conductors	04	✓	✓	✓	✓			✓
5 Conductors (CPE)	05	✓	✓	✓	✓		✓	✓
6 Conductors (CPE)	06	✓	✓	✓	✓	✓	✓	✓

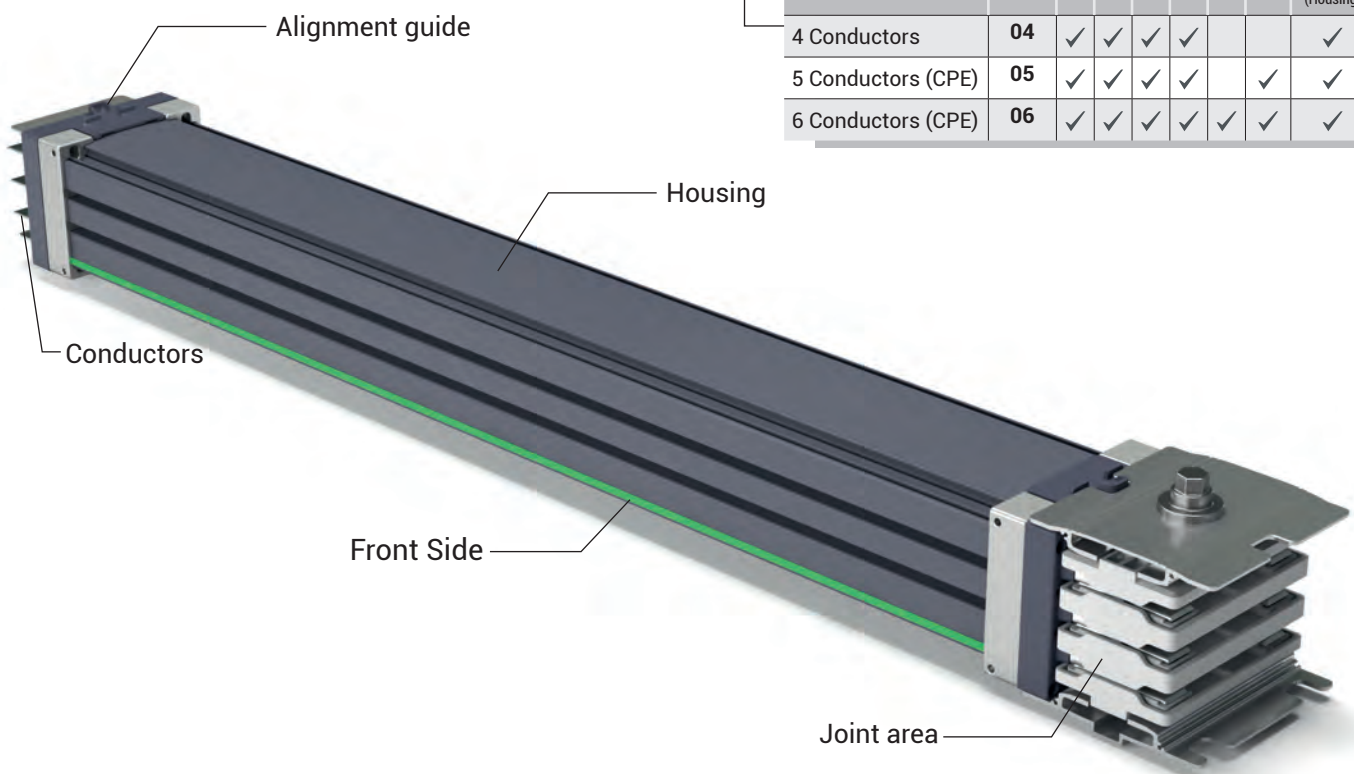

E-LINE KD



►►Standard Length

Sample Order:
250 A, Aluminium,
IP23D, 6 Conductors,
Painted
KDA 02206-B-STD

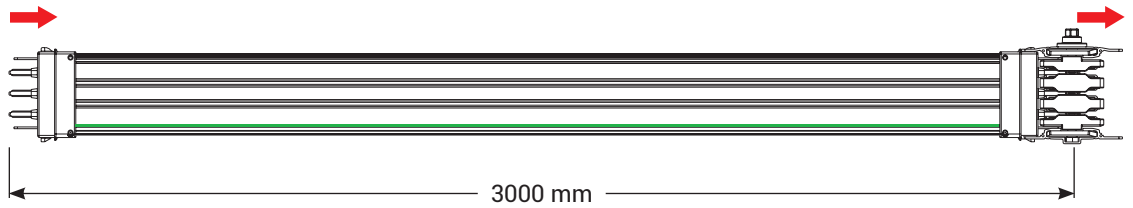

Housing Type 1: 160A...630A (Al); 250A...800A (Cu)
Housing Type 2: 1000A (Cu)

►►Special Length

Sample Order:
250 A, Aluminium,
IP23D, 6 Conductors,
Painted
KDA 02206-B-X

X=1500 mm.

Note:
Minimum Length (X)=350 mm.

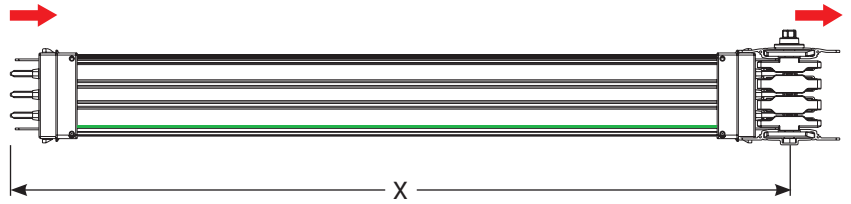

Housing Type 1: 160A...630A (Al); 250A...800A (Cu)
Housing Type 2: 1000A (Cu)

►Aluminium Closure Panel

Standard length= 2800 mm

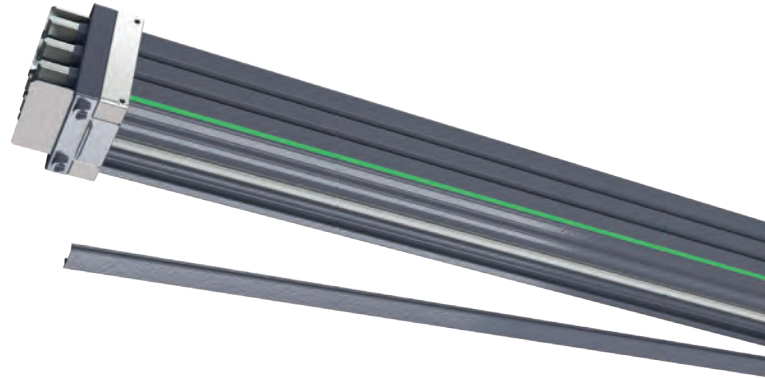
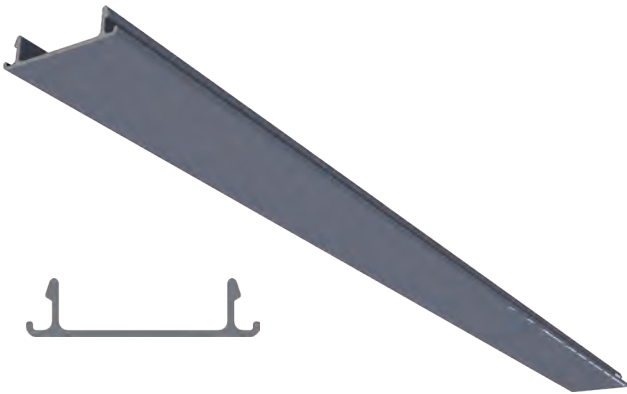

►End Closer (S)

It is used to close the end of the busbar run and included on all standard and special length of busbars.

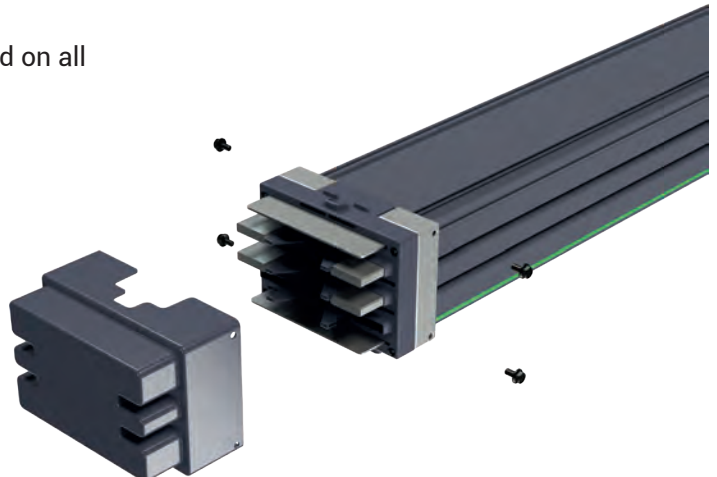
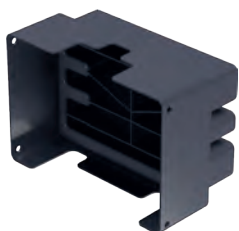

E-LINE KD

►► Elbows

► Left Elbow (L)

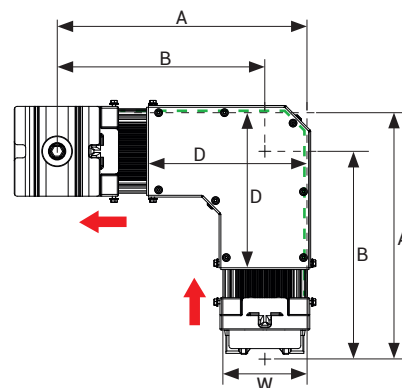
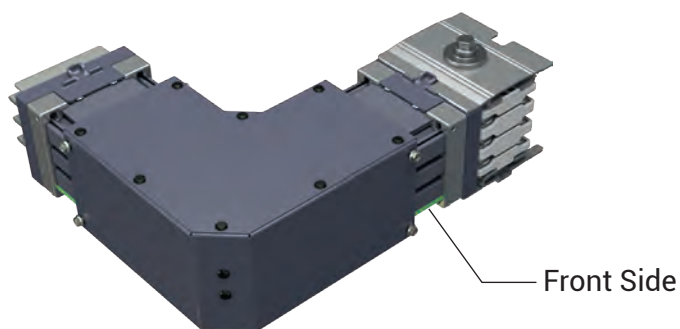

► Right Elbow (R)

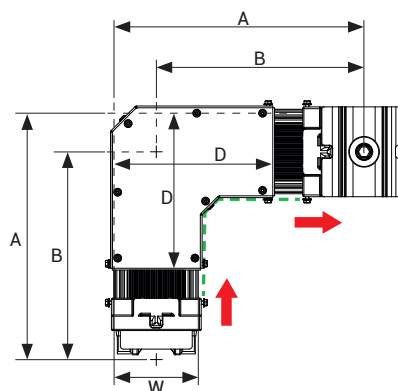
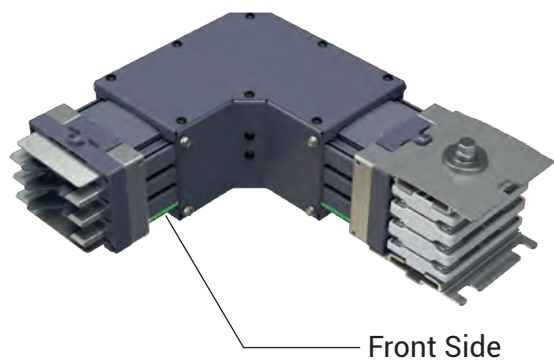

Housing Type 1: 160A...630A (Al); 250A...800A (Cu)

Housing Type 2: 800A (Al); 1000A (Cu)

	A (mm)	B (mm)	D (mm)	W (mm)
Housing Type 1	417	347	274	140
Housing Type 2	431	347	288	168

E-LINE KD



►► Elbows

► Central Feeder (TO)

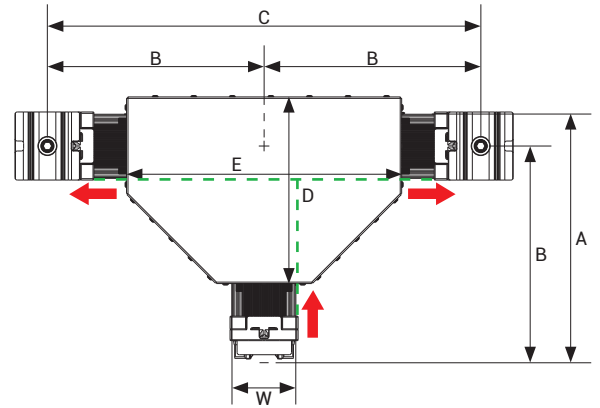
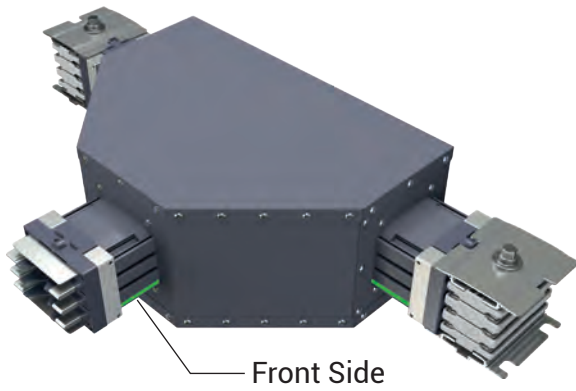

► Left Side Feeder (TYL)

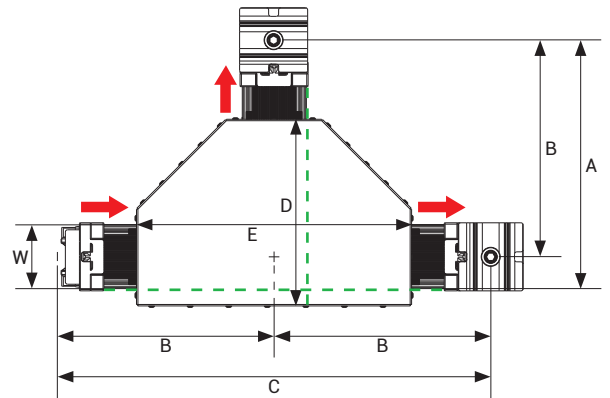
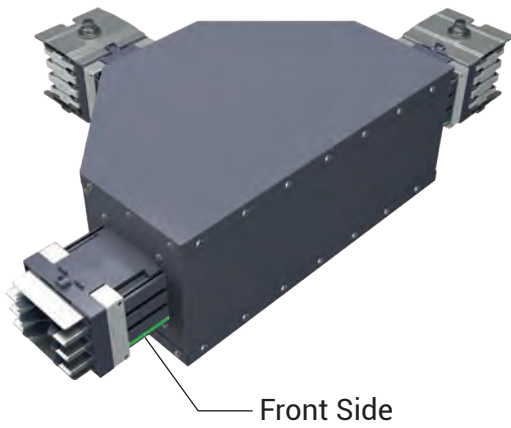

► Right Side Feeder (TYR)

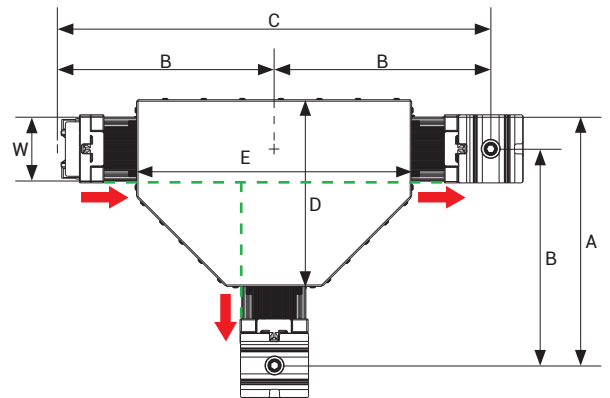
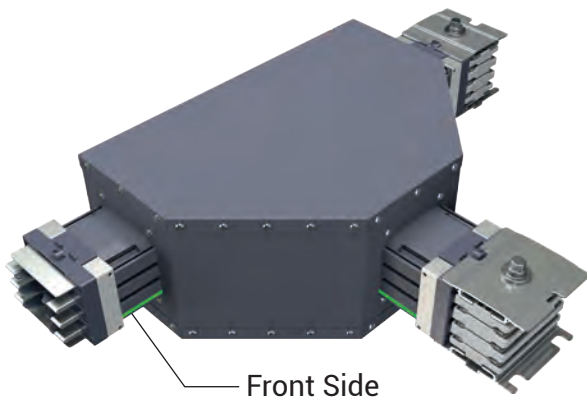

Housing Type 1: 160A...630A (Al); 250A...800A (Cu)

Housing Type 2: 1000A (Cu)

	A (mm)	B (mm)	C (mm)	D (mm)	E (mm)	W (mm)
Housing Type 1	548	478	956	411	606	140
Housing Type 2	562	478	956	425	606	168

E-LINE KD

►► Feeder Boxes 160A...630A (Al), 250A...1000A (Cu)

► Feeder Box (B10) (Orientation : Right → Left)



* Support the feeder units from corresponding junction points.

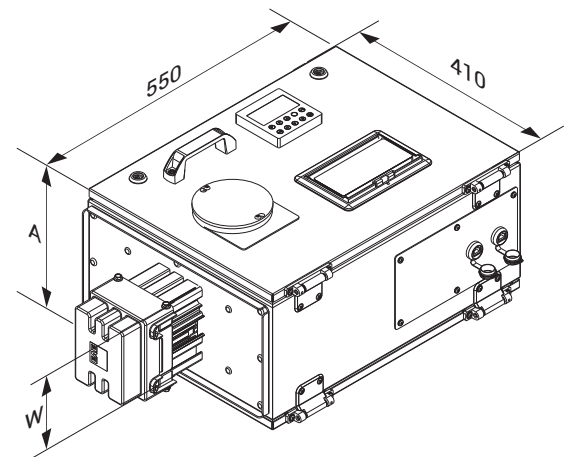
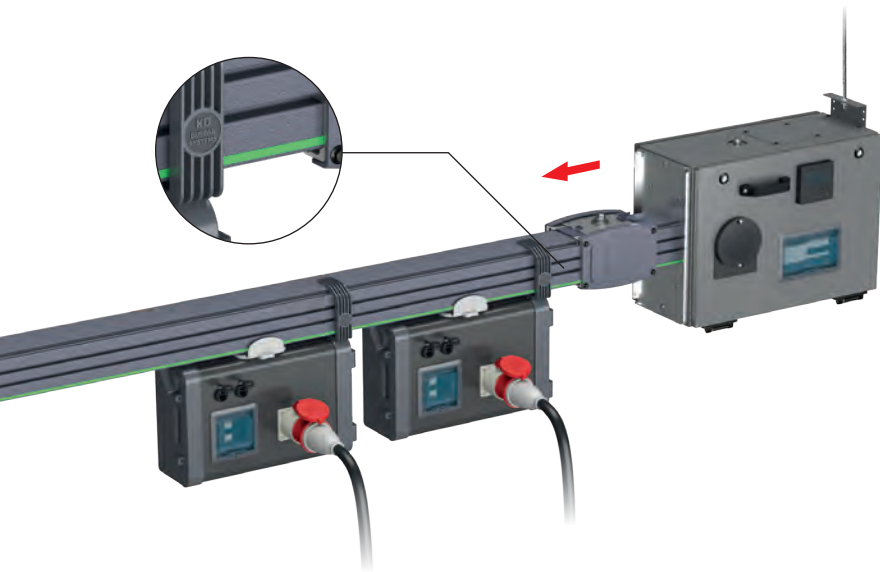
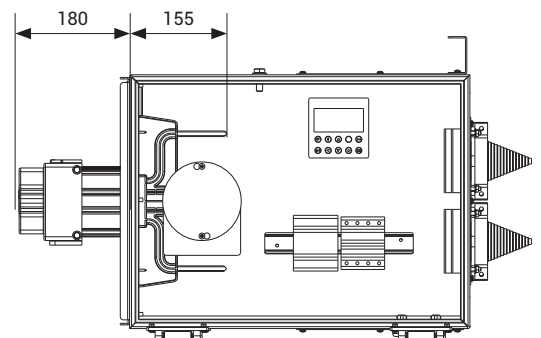

Housing Type 1: 160A...630A (Al); 250A...800A (Cu)

Housing Type 2: 1000A (Cu)

	A (mm)	W (mm)
Housing Type 1	260	140
Housing Type 2	288	168

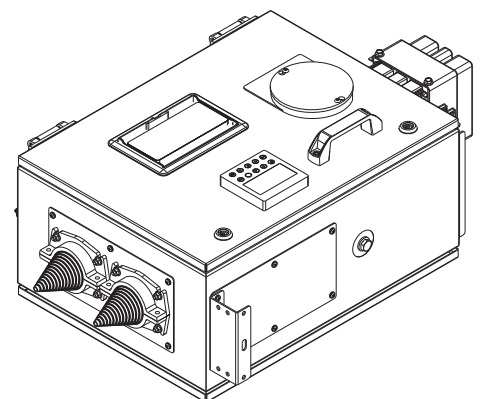

- Hinged and easily removable cover
- IR window (optional)
- Energy Monitoring (optional)

- * Please contact us for special feeder boxes.
- * All dimensions in mm.

E-LINE KD

►► Feeder Boxes 160A...630A (Al), 250A...1000A (Cu)

► Feeder Box (B11) (Orientation : Left → Right)

* Support the feeder units from corresponding junction points.

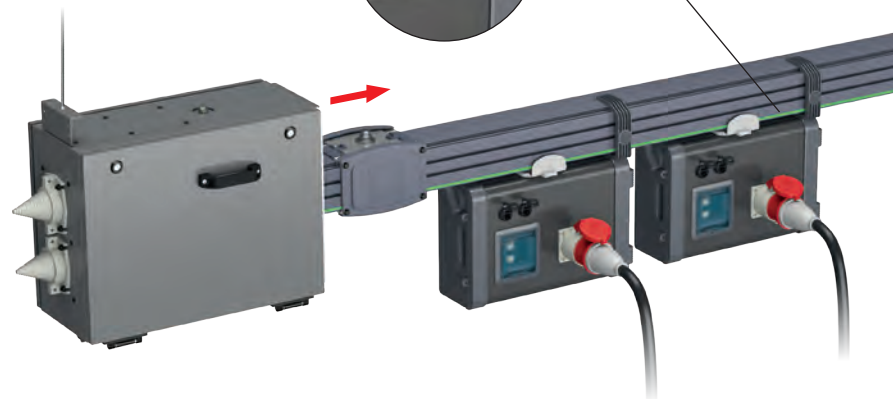
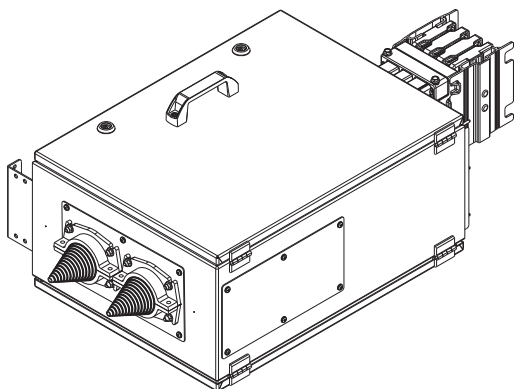
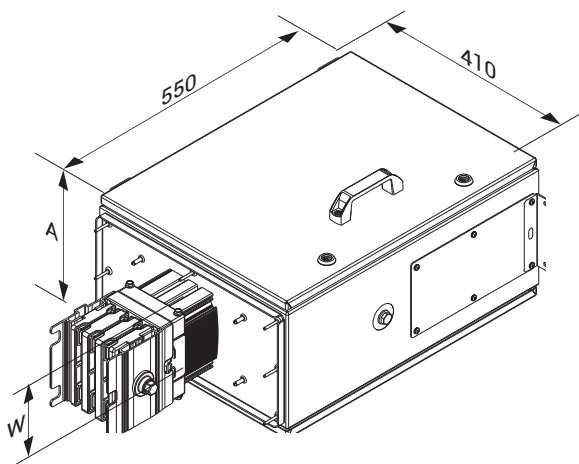
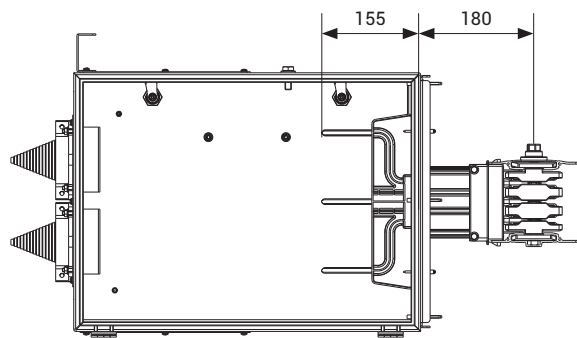

Housing Type 1: 160A...630A (Al); 250A...800A (Cu)
Housing Type 2: 1000A (Cu)

	A (mm)	W (mm)
Housing Type 1	260	140
Housing Type 2	288	168

- Hinged and easily removable cover
- IR window (optional)
- Energy Monitoring (optional)

* Please contact us for special feeder boxes.
 * All dimensions in mm.

E-LINE KD

▶▶ Tap-Off Boxes

▶KDP Terminal Box (80A)

16A/32A Single & Three Phase Circuit Breaker
16A/32A, 3P & 5P Socket / Connector with cable
RJ45 Ports (Optional for Energy Metering)



▶Type 01

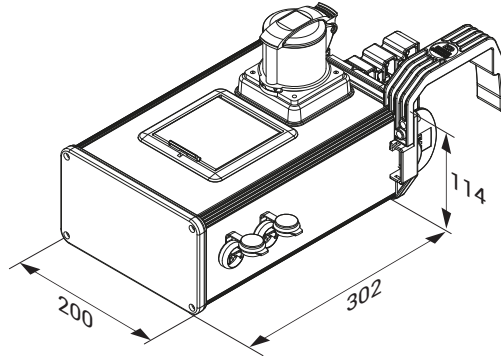

▶Type 02

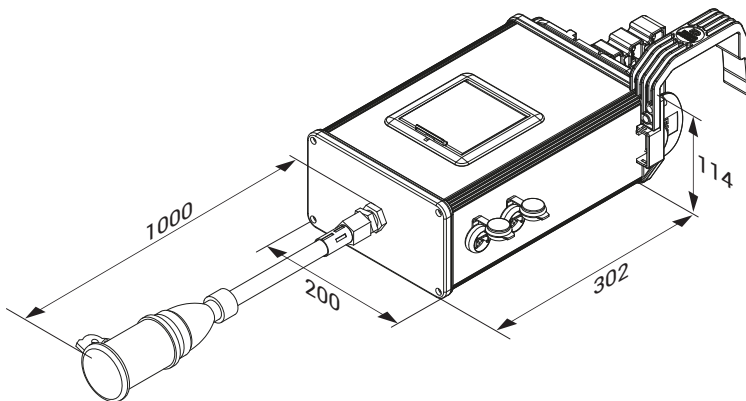

▶Type 03

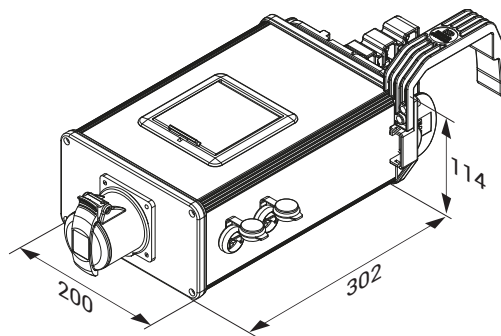

- * Please contact us for special boxes.
- * All dimensions in mm.

E-LINE KD

▶▶ Tap-Off Boxes

▶KDP Single Socket Box (125A)

16A/32A Single & Three Phase Circuit Breaker
63A Three Phase Circuit Breaker
16A/32A Single & Three Phase Socket
63A Three Phase Socket
RJ45 Ports (Optional for Energy Metering)

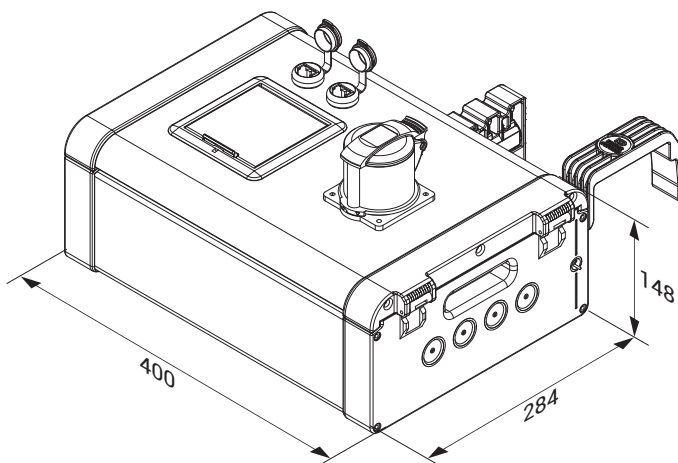

▶KDP Double Socket Box (125A)

16A/32A Single & Three Phase Circuit Breakers
16A/32A Single & Three Phase Sockets
RJ45 Ports (Optional for Energy Metering)

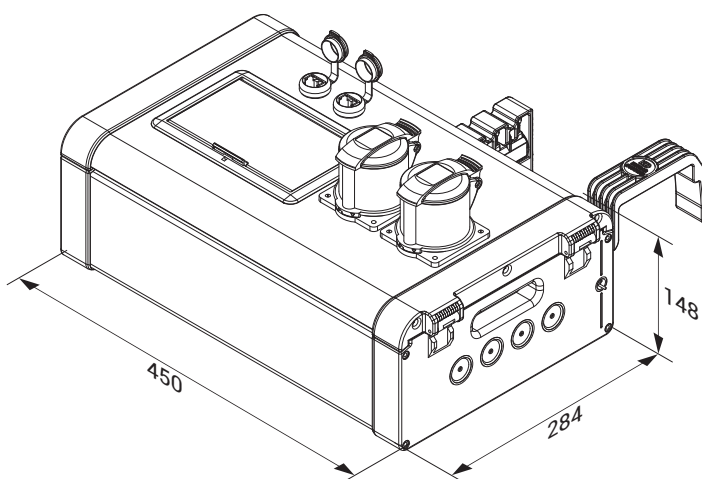
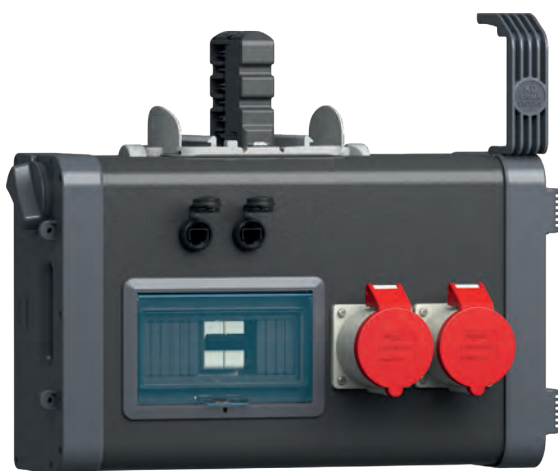

* Please contact us for special boxes.
* All dimensions in mm.

E-LINE KD

▶▶ Tap-Off Boxes

▶KDP Energy Analyzer Box (125A)



16A/32A Single & Three Phase Circuit Breakers
63A Three Phase Circuit Breaker
16A/32A Single & Three Phase Socket
63A Three Phase Socket
Energy Analyzer with Display
RJ45 Ports

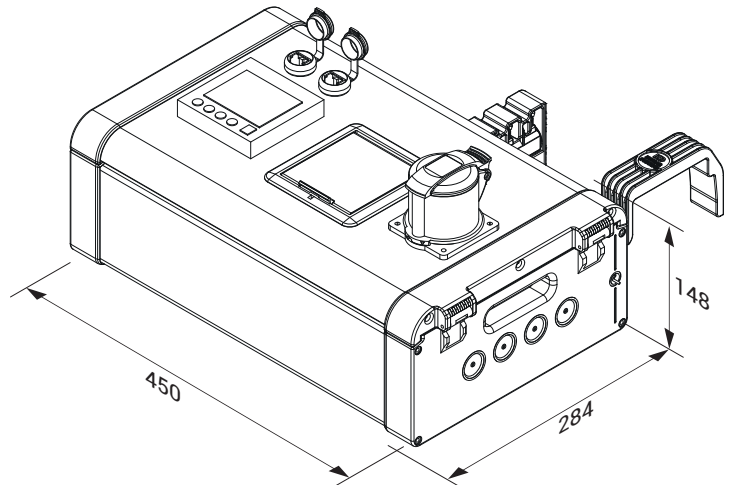

▶KDP Empty Box (125A)

Configurable up to 12 modules with RJ45 ports with optional cable gland feed.

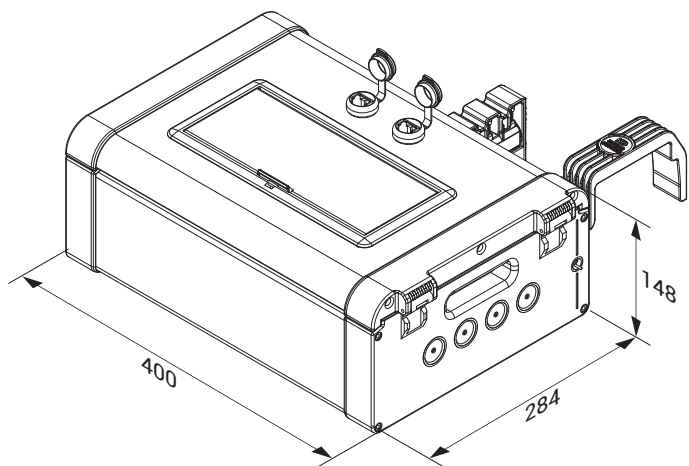
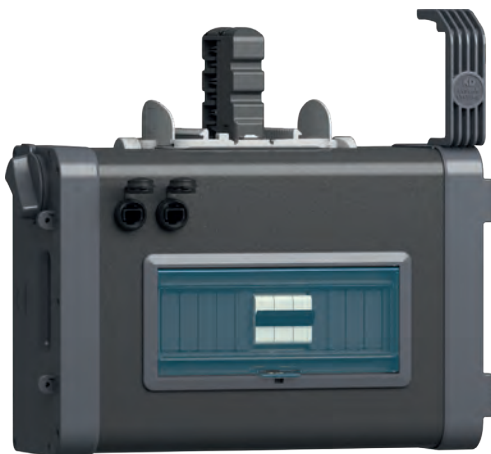

- * Please contact us for special boxes.
- * All dimensions in mm.

E-LINE KD

▶▶ Tap-Off Boxes Horizontal

▶ KDP Energy Analyzer Box Horizontal (125A)

16A/32A Single & Three Phase Circuit Breakers
63A Three Phase Circuit Breaker
16A/32A Single & Three Phase Socket
63A Three Phase Socket
Energy Analyzer with Display
RJ45 Ports

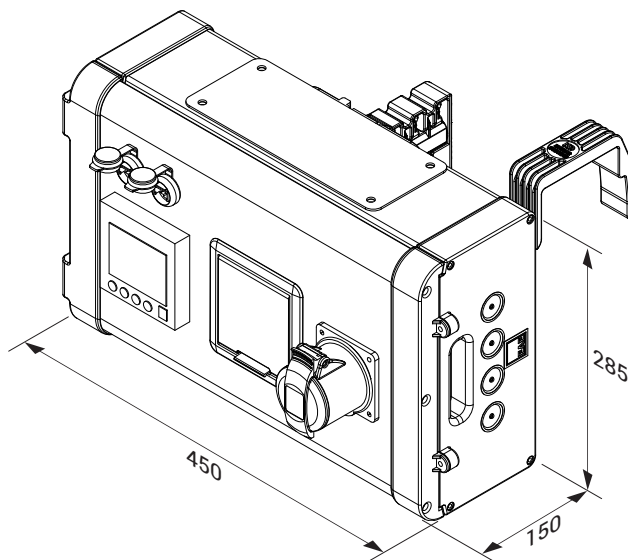

▶ KDP Empty Box Horizontal (125A)

Configurable up to 12 modules with optional cable gland feed.

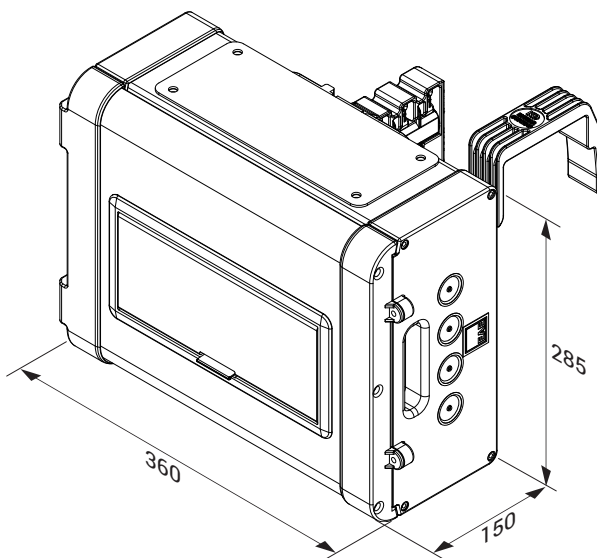

- * Please contact us for special boxes.
- * All dimensions in mm.



E-LINE KD

►► Installation

► Joint Installation

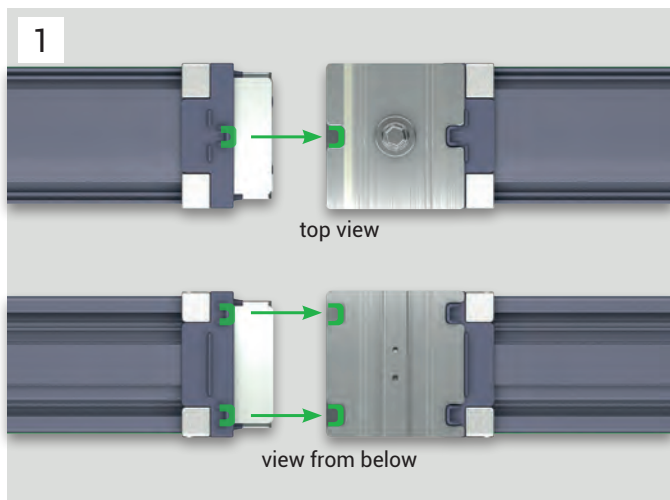

Align the busbars those with and without block joints facing each other and insert together

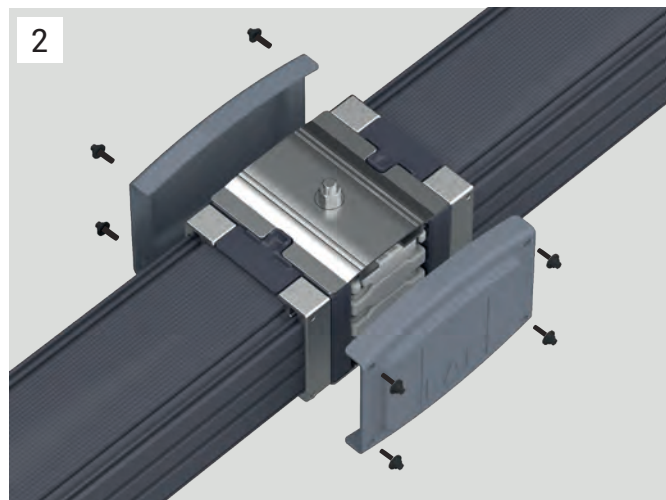

Assemble the joint cover and tighten the cover bolts

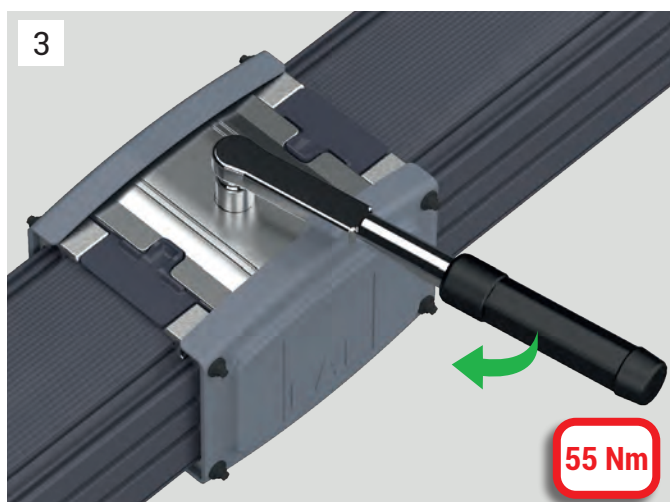

Adjust the torque wrench to 55 Nm and tighten the joint nut

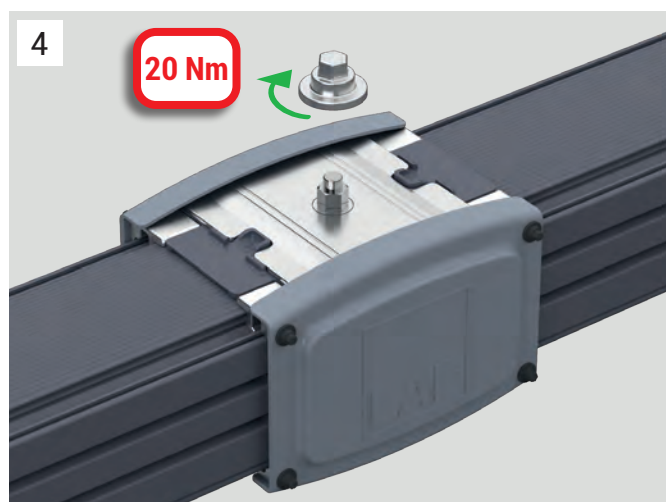

Mount the nut locking piece on the nut

E-LINE KD

►► Installation

► Tap-Off Box Installation

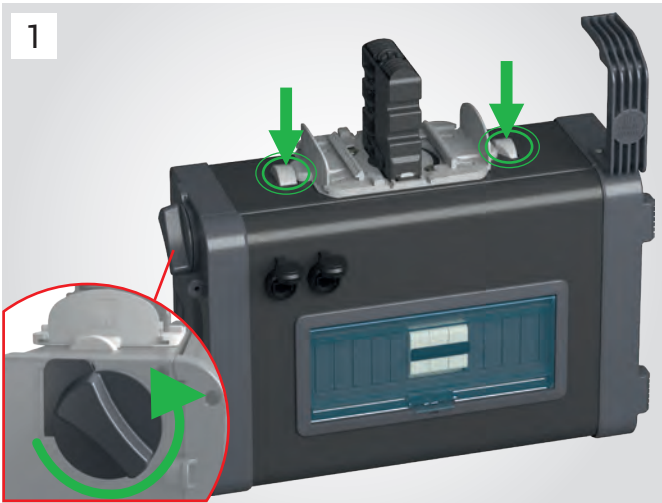

Ensure that the locking latch position is set right (as indicated), setup the installation mechanism by pressing on the claws. **If this step is not made, the box contact set may be damaged as a result of any force.**

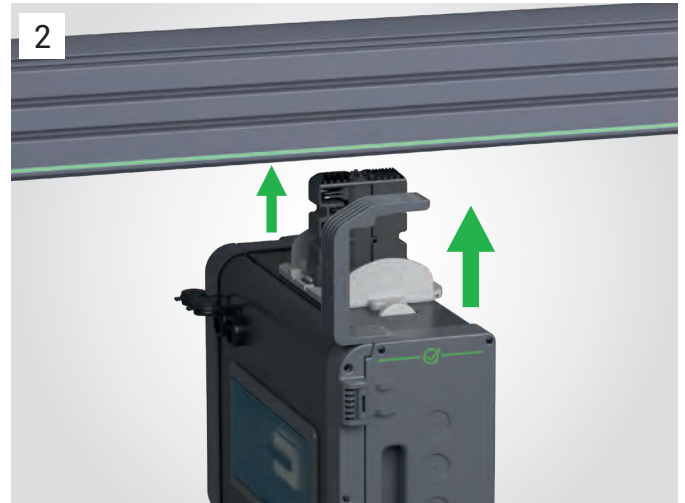

Insert the box inside the slot of the busbar by facing the mounting angle, the box label and the housing 'green' reference line on the same side

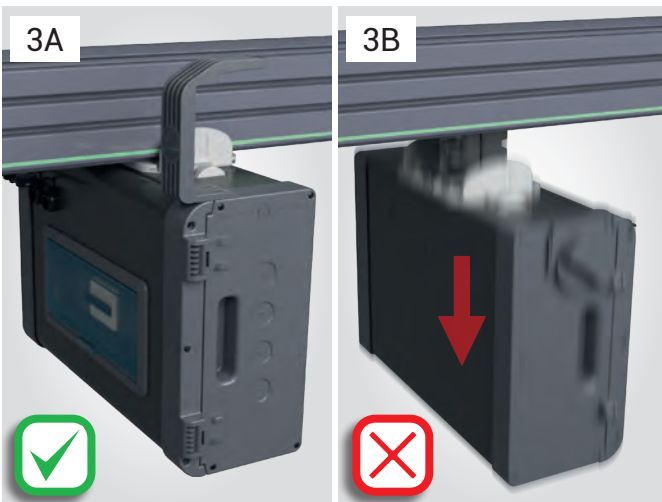

Assure that the box is inserted and locked inside the busbar slot

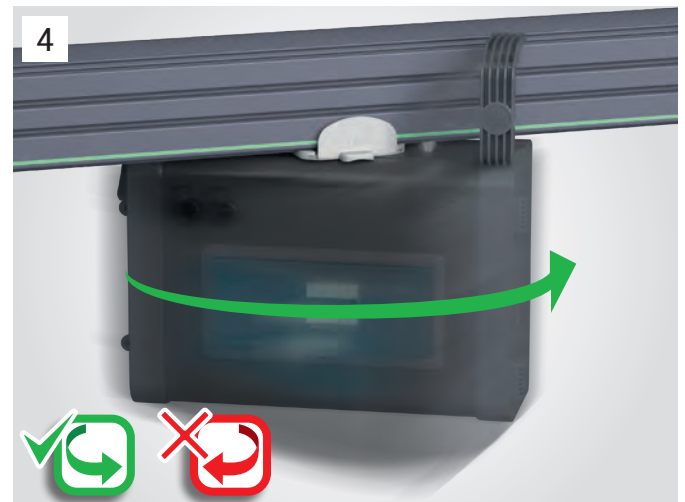

Engage the top off box by rotating in the direction of the arrow
Do not rotate the box against the direction of the arrow



Ensure that the mounting angle is correctly attached on the busbar housing



Secure the box by turning the locking latch in direction of the arrow

E-LINE KD

►► Installation

► Tap-Off Box Horizontal Installation

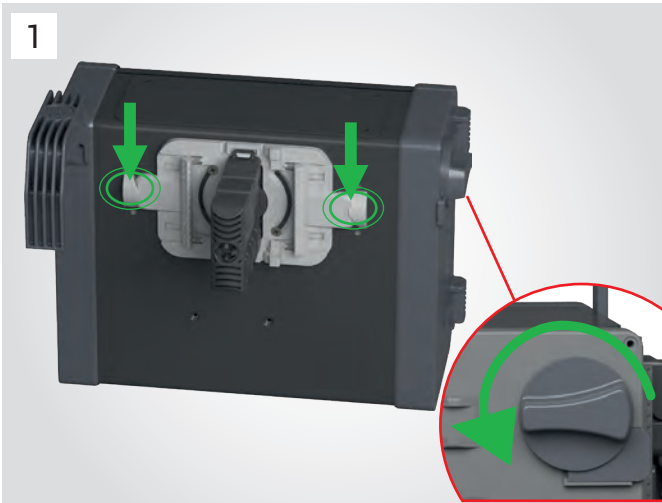

1
Ensure that the locking latch position is set right (as indicated), setup the installation mechanism by pressing on the claws

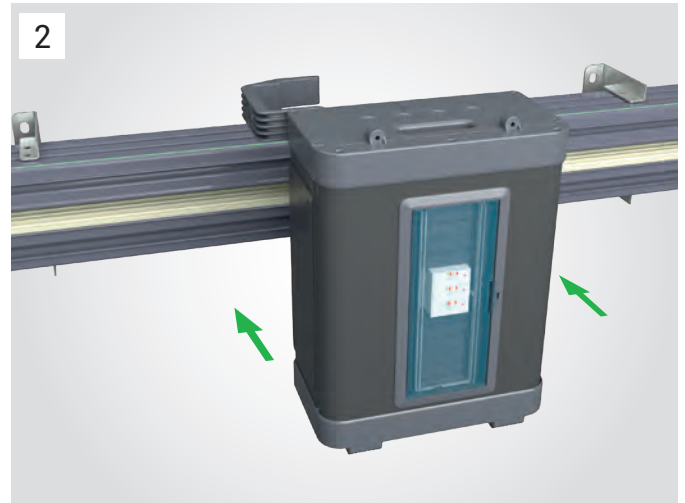

2
Insert the box inside the slot of the busbar by facing the mounting angle, the box label and the housing 'green' reference line on the same side

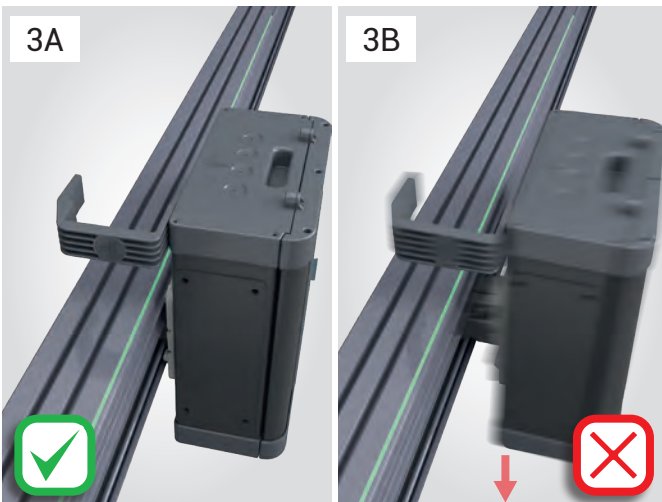

3A
3B
Assure that the box is inserted and locked inside the busbar slot

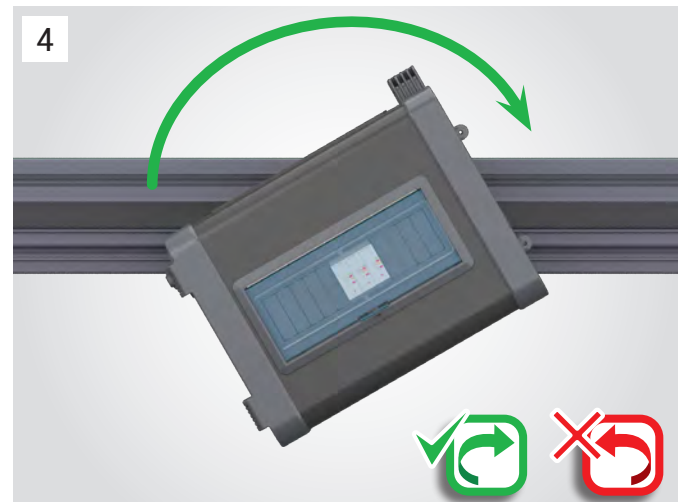

4
Engage the top off box by rotating in the direction of the arrow
Do not rotate the box against the direction of the arrow

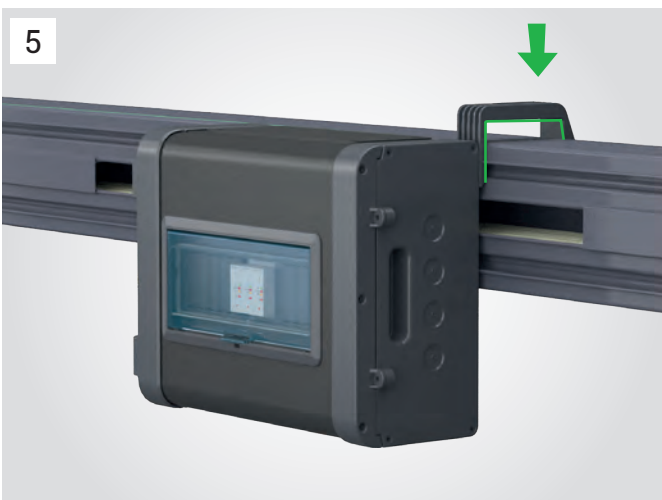

5
Ensure that the mounting angle is correctly attached on the busbar housing



6
Secure the box by turning the locking latch in direction of the arrow.

E-LINE KD



►► Fixing Elements

► Application I : Threaded Rod with Snap-In Fixing Unit

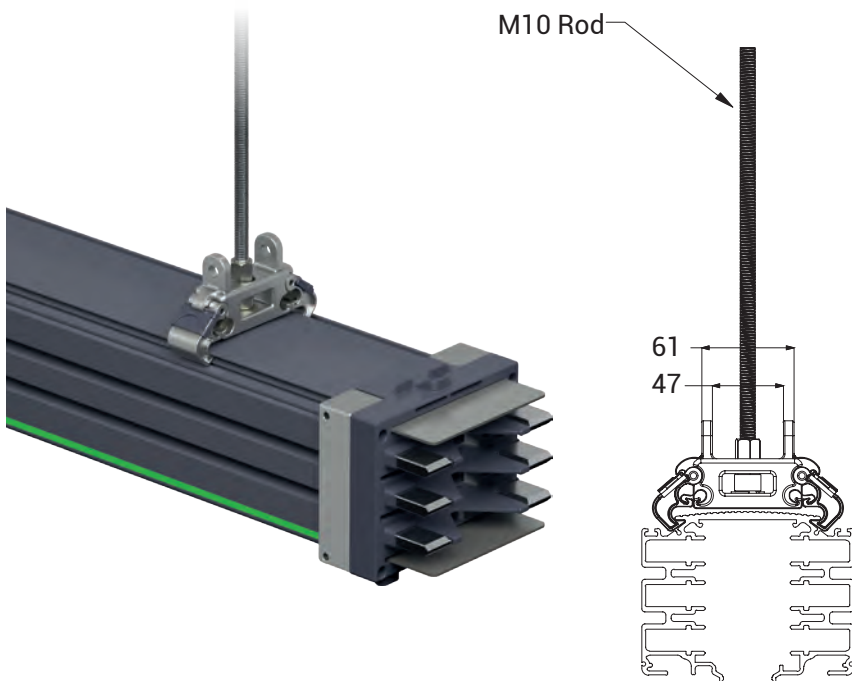

THREADED ROD SUPPORT	
KD SNAP-IN	2143683

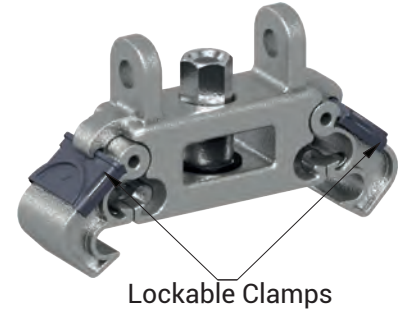

Lockable Clamps

► Fixing Unit Uninstallation

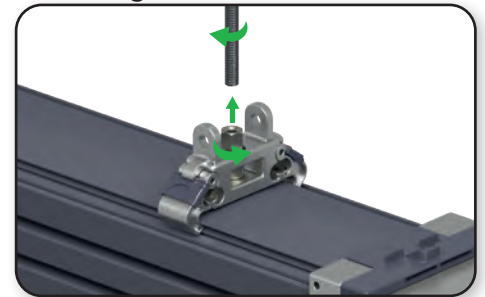

* Bolt and Nuts are included.

► Application II : TMP Ceiling Support with Snap-In Fixing Unit

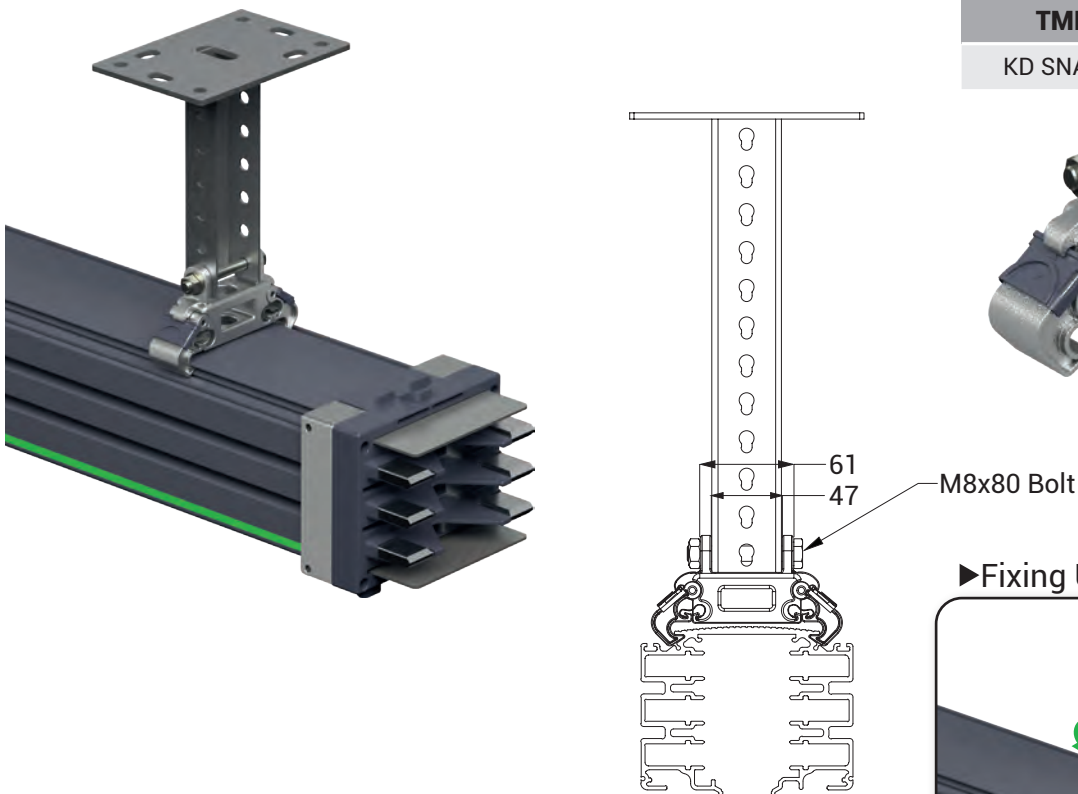

TMP CEILING SUPPORT	
KD SNAP-IN	2143682

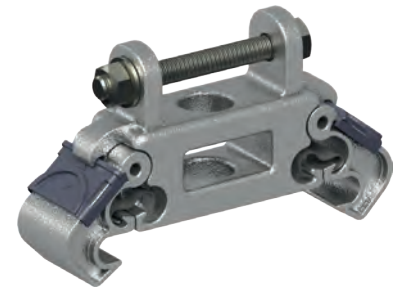

► Fixing Unit Uninstallation

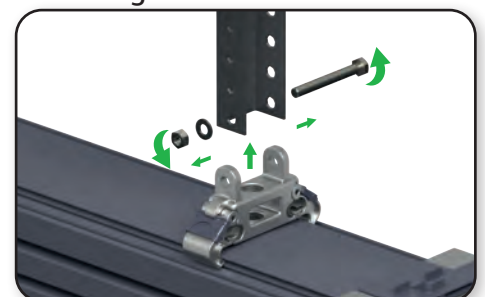

* Bolt and Nuts are included.
* All dimensions in mm.

E-LINE KD

►► Fixing Elements

► Application III : TMP Ceiling Support and Tray Bracket with Snap-In Fixing Unit

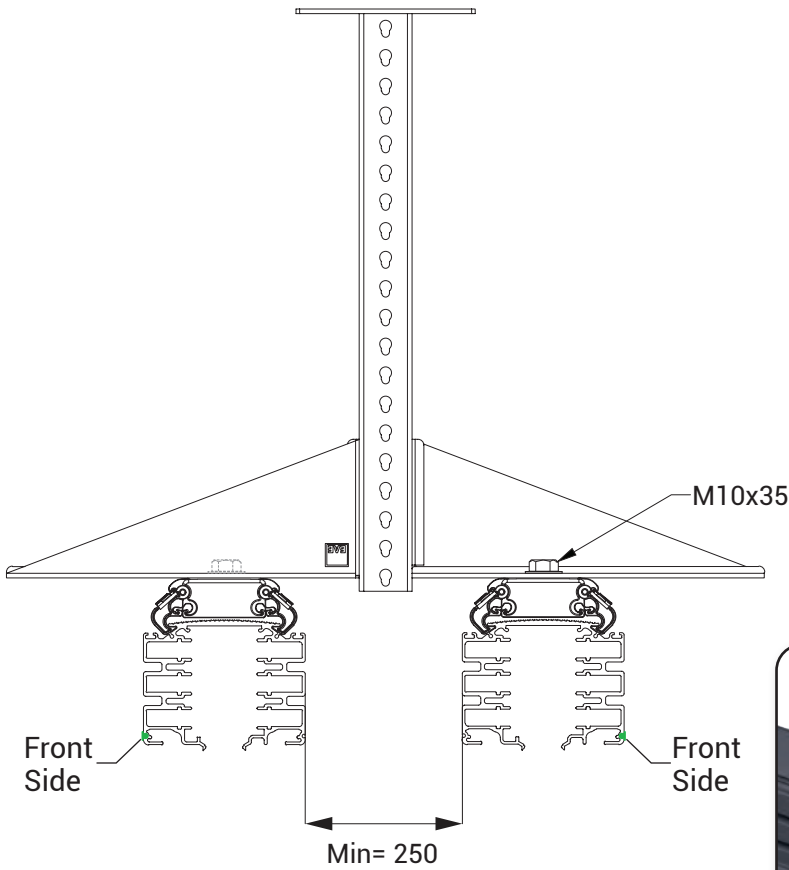
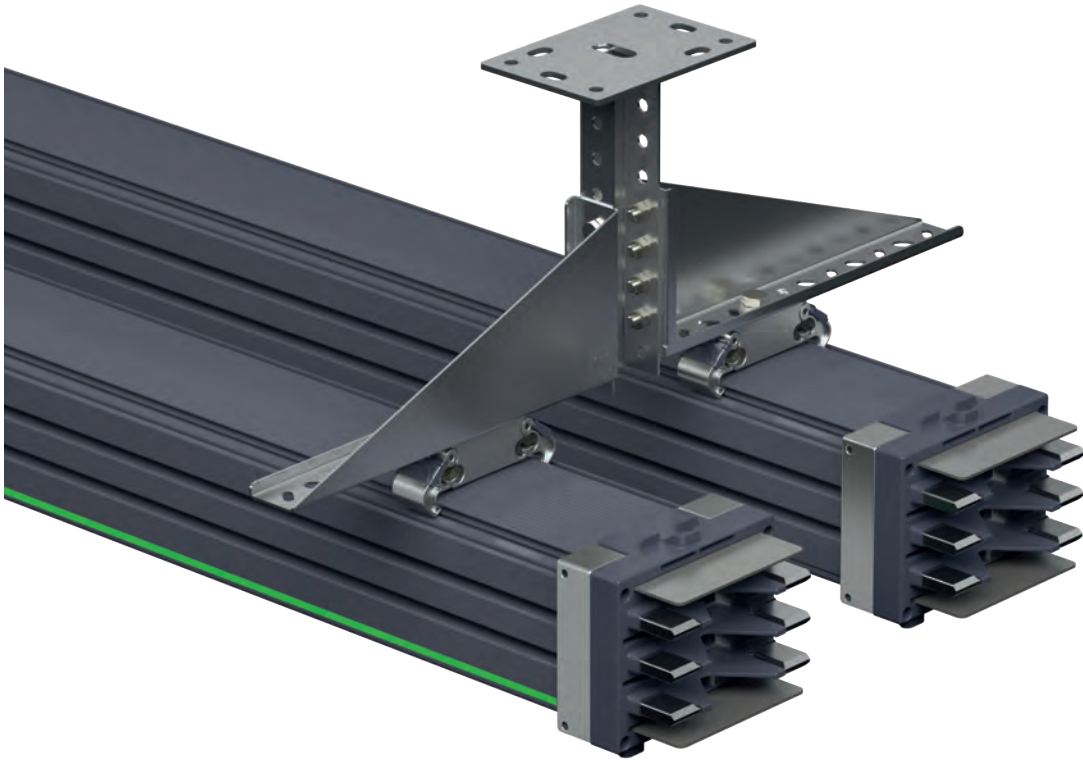

TS TRAY SUPPORT	
KD SNAP-IN	2143684

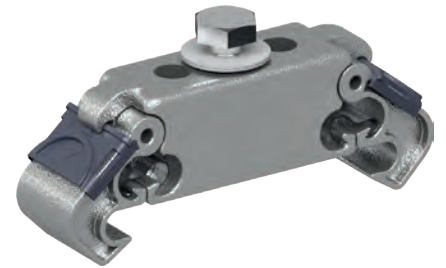

► Fixing Unit Uninstallation

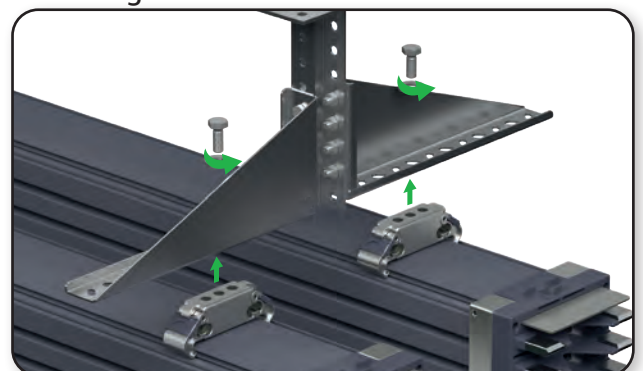

- * Bolt and Nuts are included.
- * All dimensions in mm.

E-LINE KD

►► Fixing Elements



► Ceiling Mounting Fittings

Hot Dip Galvanized After Fabrication (TS EN ISO 1461)

Description	L (mm)	T (mm)	Pulling Load (kg.)	Weight (kg./pc.)	Order Code	Pack (pc.)
TMP 42 Ceiling Support Unit	250	2	500	0,542	3008233	20
TMP 43 Ceiling Support Unit	500	2	500	0,949	3008234	10
TMP 44 Ceiling Support Unit	1000	2	500	2,131	3008235	-
TMP 45 Ceiling Support Unit	2000	2	500	3,791	3007952	-

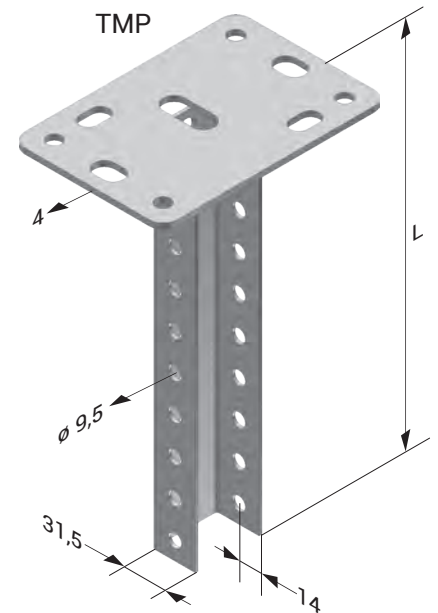

► Tray Supports

Hot Dip Galvanized After Fabrication (TS EN ISO 1461)

Description	A (mm)	T (mm)	Weight (kg./pc.)	Order Code	Pack (pc.)
TS 200	205	2	0,311	3008551	10
TS 250	255	2	0,521	3008549	10
TS 300	305	2	0,607	3008547	10
TS 400	405	2	0,781	3008545	10
TS 500	505	2	0,955	3008543	10
TS 600	605	2	1,128	3005828	10

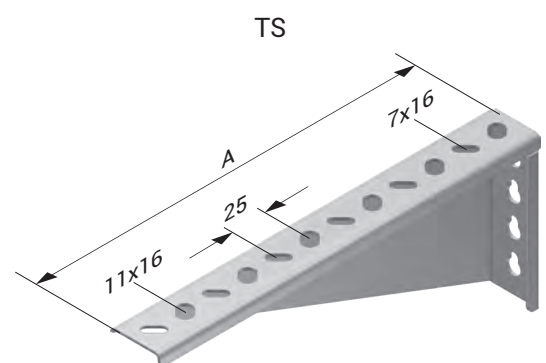

* Please contact us for special size.
* All dimensions in mm.

► Connection Accessories

Description	L (mm)	Weight (kg./pc.)	Order Code
Threaded Rod (M10)	500	0,245	5000037
Threaded Rod (M10)	1000	0,490	5000032
Threaded Rod (M10)	1500	0,735	5000031
Threaded Rod (M10)	2000	1,030	5000030
Threaded Rod (M10)	3000	1,520	5000029
Threaded Rod (M10) Electro Galvanized	500	0,245	5000172
Threaded Rod (M10) Electro Galvanized	1000	0,490	5000173
Threaded Rod (M10) Electro Galvanized	1500	0,735	5000174
Threaded Rod (M10) Electro Galvanized	2000	1,030	5000175
Threaded Rod (M10) Electro Galvanized	3000	1,571	5000301

Description	Weight (kg./pc.)	Order Code
Extension Nut (M10) Lacquered	0,070	1004312

M10 Rod

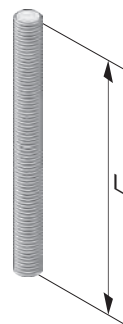

Extension Nut



* Please contact us for special size.
* All dimensions in mm.

►►Measuring a Special Length

After installation of standard busbar 3000 mm lengths, you will be in need of special lengths which are smaller than 3000 mm. The minimum length for these special elements can be 350 mm. Please measure the lengths of these modules as shown below.

Length A is measured between housing of 2 busbars in mm. A. The special length is calculated by deducting 97 mm from this measured length.

$X = A - 97 \text{ mm}$

$X = \text{Length of Special Busbar}$ (The busbar module will be manufactured as per X value.)

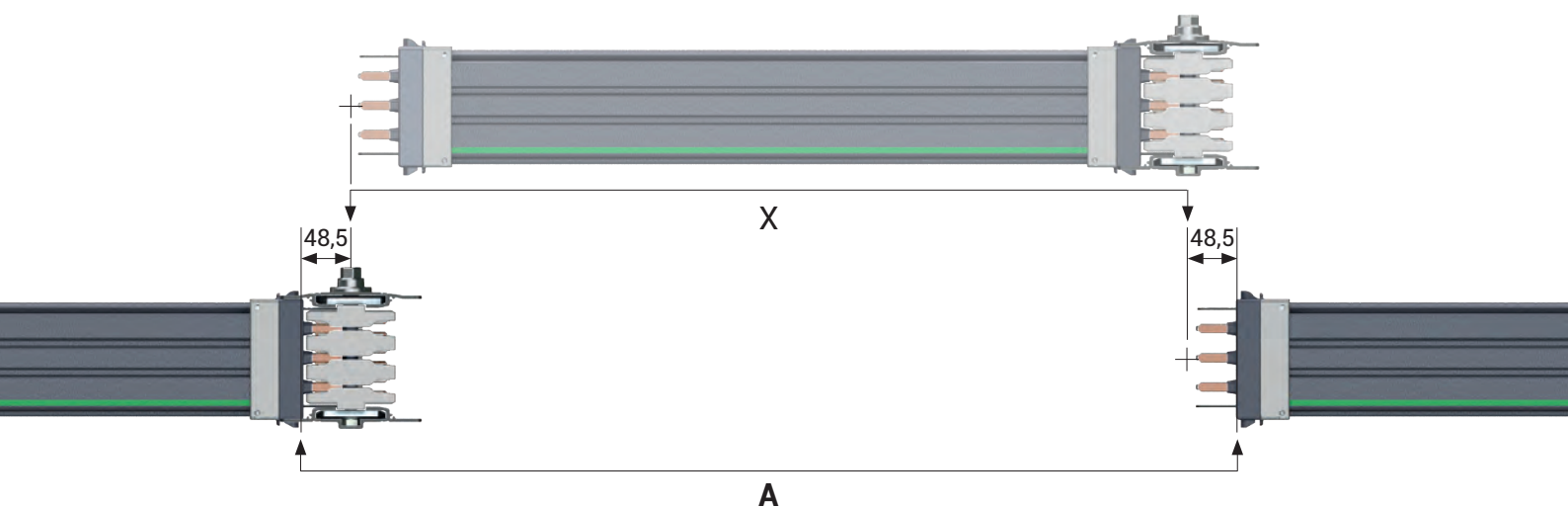

* All dimensions in mm.

E-LINE KD

►► Busbar Installation Applications

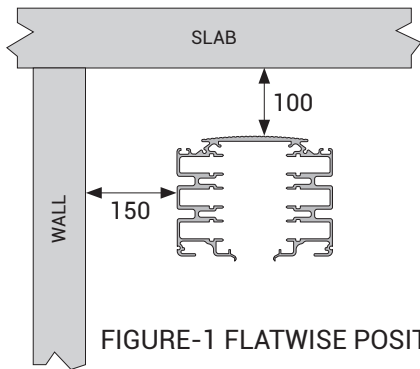

FIGURE-1 FLATWISE POSITION

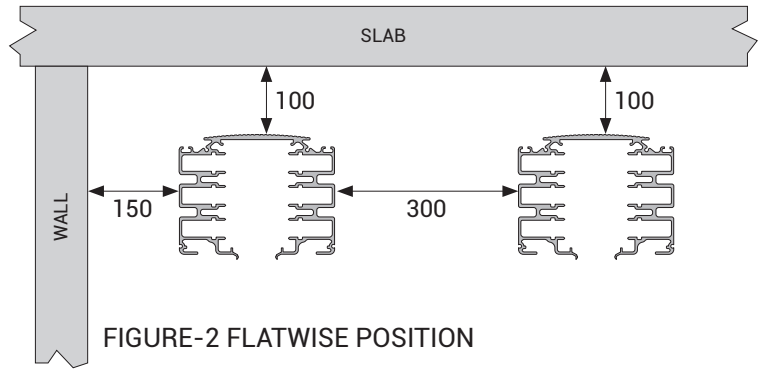

FIGURE-2 FLATWISE POSITION

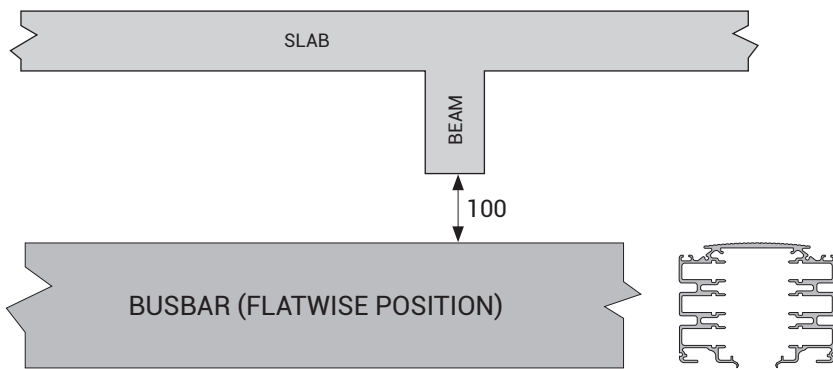

FIGURE-3 CROSSING UNDER A BEAM HORIZONTAL POSITION

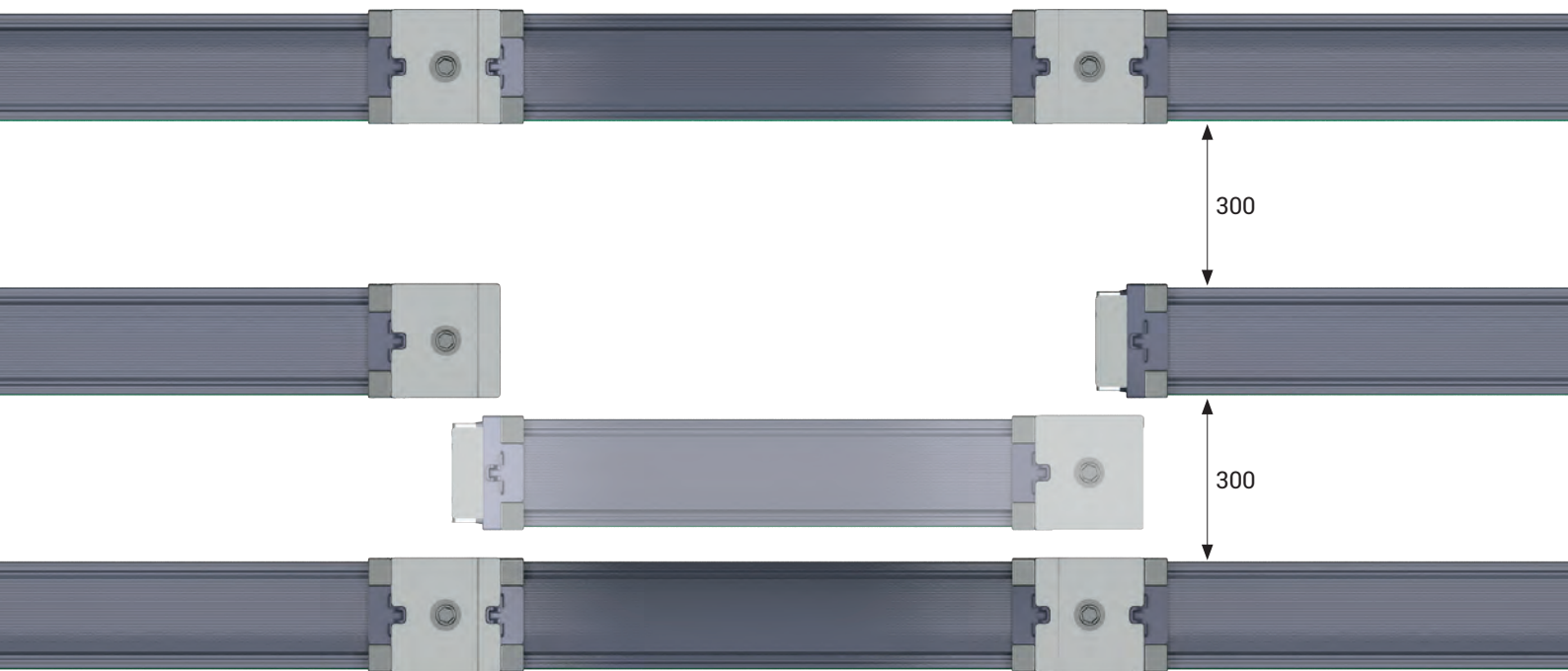

FIGURE-4 MINIMUM DISTANCE BETWEEN BUSBAR RUNS

* All dimensions in mm.



CE DECLARATION OF CONFORMITY

Product Group E-Line KD Data Rack Busbar

Manufacturer EAE Elektrik Asansor End. Insaat San. ve Tic. A.S.
Akcaburgaz Mahallesi, 3114. Sokak,
No:10 34522 Esenyurt-Istanbul-Turkey

The objects of the declaration described below is in conformity with the relevant Union harmonisation legislation. This declaration of conformity is issued under the sole responsibility of the manufacturer.

Standard:

TS EN 61439-6

Low-voltage switchgear and controlgear assemblies - Part 6: Busbar trunking systems

IEC 61439-6

Low-voltage switchgear and controlgear assemblies - Part 6: Busbar trunking systems (busways)

CE - Directive:

2014/35/EU "The Low Voltage Directive"

2014/30/EU "(EMC) Electromagnetic Compatibility Directive"

2011/65/EU "RoHS Directive"

Technical Document Preparation Official:

EAE Elektrik Asansor End. Insaat San. ve Tic. A.S.
Akcaburgaz Mahallesi, 3114. Sokak, No:10 34522 Esenyurt-Istanbul

Emre GÜRLEYEN

Date

20.04.2019

Document Authorized Signatory

Elif Gamze KAYA OK
Deputy General Manager



160A ... 1000A DATA RACK BUSBAR PRODUCT OVERVIEW (E-LINE KD)

1- Standards & Certification:

- Busbar system shall be designed and manufactured as per IEC 61439-6 standard, which requires below listed tests. Each busbar rating shall have a separate type test certificate from an independent internationally accredited laboratory including below tests:
 - 10.2- Strength of material and parts, 10.2.2- Resistance to corrosion, 10.2.3- Properties of insulating materials, 10.2.3.1- Verification of thermal stability of enclosures, 10.2.3.2- Verification of resistance of insulating materials to abnormal heat and fire due to internal electric effects, 10.2.6- Mechanical impact, 10.2.7- Marking, 10.2.101- Ability to withstand mechanical loads , 10.2.101.1- Test procedure for a straight busbar trunking unit, 10.2.101.2- Test procedure for a joint, 10.2.101.3- Resistance of the enclosure to crushing, 10.3- Degree of protection of assembly, 10.4- Clearances and creepage distances, 10.5-Protection against electric shock and integrity of protective circuits, 10.5.2- Effective earth continuity between the exposed conductive parts of the assembly and the protective circuit, 10.5.3- Short-circuit withstand strength of the protective circuit, 10.9- Dielectric properties, 10.9.2- Power-frequency withstand voltage, 10.9.3- Impulse withstand voltage, 10.10- Verification of temperature rise, 10.11- Short- circuit withstand strength, Annex BB Phase conductor characteristics, Annex CC Fault-loop zero-sequences impedances, Annex DD Fault-loop resistances and reactances.
- Busbar system shall have CE marking.
- The manufacturer of busbar system shall have ISO 9001 and ISO 14001 certification.
- Each product shall have a "Type Label" including coding system, which identifies the brand, type of the unit, number of conductors and electrical details. The same coding shall be on the related certificate and catalogue.

2- Electrical Characteristics

- Busbar systems nominal insulation voltage shall be 1000 V.

2.1- Housing

- Conductors shall be packed and placed into the housing.
- Housing shall be made of thermal processed, extruded aluminium, RAL7012-Electrostatic painted.

2.2- Conductors

- Aluminium or Copper conductors overall isolated and tin plated.
- Aluminium conductors between 160A – 630A.
- Copper conductors between 250A –1000A.
- Busbar system shall have the following number of conductors and wire configuration;
 - 6 Conductors: (6 full size conductors CPE (100% earth conductor + double neutral + housing)),
 - Phase conductors and neutral conductor shall have the same cross-section and they shall be insulated.
 - Aluminium conductors shall be of EC grade aluminium. Minimum conductivity shall be $34\text{m}/\text{mm}^2 \cdot \Omega$.
 - Copper conductors shall be minimum 99,95% electrolytic copper. Minimum conductivity shall be $56\text{m}/\text{mm}^2 \cdot \Omega$.

2.3- Insulation

- Insulation system shall be suitable for 1.000V continuous operation. Conductor size shall be designed so that temperature rise on the conductors shall not exceed 100°C degree at nominal current, which helps to global heating problem. With this reason, insulation class shall be selected as "B class".

2.4-Joint Structure

- Electrical and mechanical connection shall be made by placing conductor joints into the joint blocks of the connected conductors and followed by tightening and fastening of the joint bolts.

2.5-Protection

- Protection degree of the housing and joints shall be IP23D.

2.6-Acessories

- Busbar system shall have all necessary accessories (elbows, panel-transformer connections, etc.) Manufacturer shall supply special dimensioned units in short time, if the project conditions requires

3-Tap Off Boxes

- The Tap off boxes shall be Plug-nPlay type.
- Plug-n-Play tap off boxes shall be suitable to install or remove from busbars without switching off the power on the busbar.
- Plug-n-Play tap off boxes shall be suitable to install or remove anywhere alongside the busbar.
- The Tap-Off Box contacts shall be protected with a cover
- The Tap-Off contacts shall be heat cycle tested
- Contacts of plug-in tap off box shall be silver plated.
- The special locking mechanism of the Tap-Off Boxes shall ensure to carry the weight of the plug-in box and cables by the busbar housing
- While inserting the contacts of plug-in tap off box, earth contact shall make the first touch. While removing, it shall be disconnected last.
- Tap off boxes shall be manufactured of epoxy painted aluminium.
- The Tap-Off Boxes shall be equipped with a safe alignment mechanism to ensure correct installation and operation

4-Busbar Fixing&Mounting System

- The Busbars shall be easily installed and positioned through their entire lengths with the "Snap-In Fixing Units" by inserting into the guiding slots on top of the housing.
- To ensure flexible positioning of the Busbars, each single busbar length shall easily slide independently on the "Snap-In Fixing Units" through the guiding slots.
- To maintain the mounting security, the "Snap-In Fixing Unit" clamps shall be lockable.
- For various mounting practices the "Snap-In Fixing Units" shall be available with threaded rod, ceiling support and/or with tray brackets options

5-Installation and Commisioning

- Busbar systems shall be installed as per Single-Line drawings respect to required ampere rates and manufacturer installation guide (torque values, lockers, etc.). Electrical installer shall run an insulation test after installation, according to manufacturer's test procedures. The results of the test shall be reported to the manufacturer and minimum insulation value shall be 1 Mohms.

E-LINE KD

►►Project Design Form



Component List	
Item	Quantity
Component	

Company :
Project :
Project No :

Name :
Date :
Signature :

Prepared by

Please duplicate this page for your own use.

E-LINE KD

►► Project Design Form



Component List	Quantity	Component
Item		

Company :
Project :
Project No :

Name :
Date :
Signature :
Prepared by



Please duplicate this page for your own use.

EAE Elektrik A.S.
Head Office
Akcaburgaz Mahallesi,
3114. Sokak, No:10 34522
Esenyurt - Istanbul - TURKEY
Tel: +90 (212) 866 20 00
Fax: +90 (212) 886 24 20

EAE DL 3 Factory
Busbar
Gebze IV Istanbul Makine ve Sanayicileri
Organize Bolgesi, 6. Cadde,
N: 6 41455 Demirciler Koyu,
Dilovası - Kocaeli - TURKEY
Tel: +90 (262) 999 05 55
Fax: +90 (262) 502 05 69

Please visit our website for the updated version of our catalogues.
www.eaeelectric.com



Catalogue 55 -Eng. / Rev 11 1000 Pcs. 16/10/2023
D.S.

EAE has full right to make any revisions or changes on this catalogue without any prior notice.

